

RS8 BLADE SHARPENER

RAPIDBLADE SHARPENER



OPERATOR'S MANUAL

0001565-M-EN: Rev C
Publication Date: 13-May-2025

**WOODLAND
MILLS**

WE GO BEYOND.™

TABLE OF CONTENTS

TABLE OF CONTENTS	1
INTRODUCTION	3
KEY SYMBOLS	3
SAFETY REGULATIONS	4
TECHNICAL SPECIFICATIONS	4
OVERALL DIMENSIONS	5
SHORTEST SUPPORT ARM POSITION	5
LONGEST SUPPORT ARM POSITION	6
COMPONENT LISTS	7
TO-SCALE HARDWARE	8
BOLTS & SCREWS	8
WASHERS	9
NUTS	9
ASSEMBLY	10
1. TOOLS REQUIRED	10
2. MOUNTING STYLE	11
3. STAND	12
A. LEGS	12
B. LEGS-TO-MOUNTING BASE (FRONT)	13
C. LEGS-TO-MOUNTING BASE (REAR)	14
4. CONTROL BOX	16
A. CONTROL BOX-TO-STAND	16
B. ADVANCER	17
5. GRINDING HEAD	18
A. GRINDING HEAD-TO-CONTROL BOX	18
B. GRINDING DISC	19
C. DEPTH ADJUSTMENT ROD	20
D. GRINDING SHIELD	21
6. SUPPORT ARMS	22
A. INNER SUPPORT ARMS	22
B. ADJUSTABLE OUTER SUPPORT ARMS	23
7. WORKBENCH MOUNTING (OPTIONAL)	25
BATTERY	26
MAINTENANCE	27
CLEANING AND INSPECTION	27
SAW BLADE GEOMETRY	28
SHARPENING GUIDELINES	29

GULLET RADII _____	29
BACK AND HOOK ANGLES _____	29
PROFILING THE GRINDING DISC _____	30
FUSES _____	32
OPERATION _____	33
1. SETTING THE HOOK ANGLE _____	33
2. INSTALLING THE BLADE _____	34
A. BLADE SUPPORTS _____	34
B. BACK REST _____	35
C. GUIDE PLATE _____	35
3. CALIBRATING THE ADVANCEMENT _____	36
A. CONNECT THE BATTERY _____	36
B. ADVANCE THE BLADE _____	37
C. ROTATE THE GRINDING HEAD DOWN _____	38
D. FINE-TUNE THE ADVANCEMENT _____	40
E. FINE-TUNE THE GRINDING HEAD MOVEMENT _____	41
4. SHARPENING _____	43
A. ADVANCE THE BLADE _____	43
B. SET GRIND DEPTH _____	44
C. POSITION THE AUTO-STOP _____	45
STORAGE _____	47
REPLACEMENT PARTS ORDERING _____	48
TROUBLESHOOTING _____	49
EXPLODED ASSEMBLY VIEWS _____	50
STAND _____	50
CONTROL BOX _____	51
GRINDING HEAD _____	52
CONTROL HEAD TO STAND _____	53
ACCESSORIES AND LABELS _____	54
PARTS LIST _____	55
NOTES _____	57

INTRODUCTION

This operator's manual describes in detail how the bandsaw blade sharpener is used and maintained and how servicing is to be carried out. It also describes the measures to be taken for maximum safety and how the safety features are designed and function, as well as how they are inspected, maintained, and repaired if necessary.

Note: The section dealing with safety must be read and understood by all those who install, use, or repair the sharpener.

The operator's manual comprises installation, usage, and the maintenance procedures to be performed by the operator. More comprehensive servicing or troubleshooting should not be performed unless instructed by a service technician.

The operator's manual describes all the requisite safety features and should be read and understood by the user before the sharpener is assembled.

Symbols and warning signs shown on this page can be found in this operator's manual and on the sharpener. If a decal on the sharpener has been damaged or is worn, a new warning decal must be applied as soon as possible in order to ensure the greatest possible safety when using the sharpener.

The bandsaw blade sharpener shall only be used for bandsaw blades with hardened teeth. The bandsaw blade width shall be between 1 to 1-¼ in [25 to 32 mm].

KEY SYMBOLS

MANDATORY ACTIONS

The symbols below used in this operator's manual:



Read the manual carefully before attempting to use the bandsaw blade grinder.



Wear protective gloves.



Wear protective eyewear.

WARNINGS

The decal with the symbols below are found on the bandsaw blade grinder:



Exercise caution.

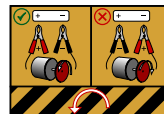

Battery polarity warning.

SAFETY REGULATIONS



The following safety regulations apply to the sharpener:

- Do not store gasoline/petrol in the vicinity of the sharpener. Sparks from the grinding disc or the electrical connection could ignite it.
- The bandsaw blade is sharp and can cause injury. Always wear protective gloves when handling blades.
- The grinding disc must be turned off when adjusting the sharpener.
- Ensure the battery polarity connections are correct. The grinding disc could come loose and cause personal injury if it rotates in the wrong direction.
- Ensure the grinding disc shows no signs of cracking and is secured tightly to the spindle. Stop the grinding disc immediately if abnormal vibration occurs.
- Always wear protective eyewear while grinding!

TECHNICAL SPECIFICATIONS

Item	Sharpener Specification
Motor	12 VDC
Power Source	12 V Battery (Customer-Supplied)
Blade Width Range	1 to 1-¼ in [25 to 32 mm]
Blade Pitch Range	¾ to 1 in [19 to 25 mm]
Blade Thickness Range	0.035 to 0.055 in [0.89 to 1.4 mm]
Preset Blade Angles	7°, 10°, 14°
Shipping Weight	29 lb [13.2 kg]
Grinding Speed	8 Teeth per Minute

OVERALL DIMENSIONS

SHORTEST SUPPORT ARM POSITION

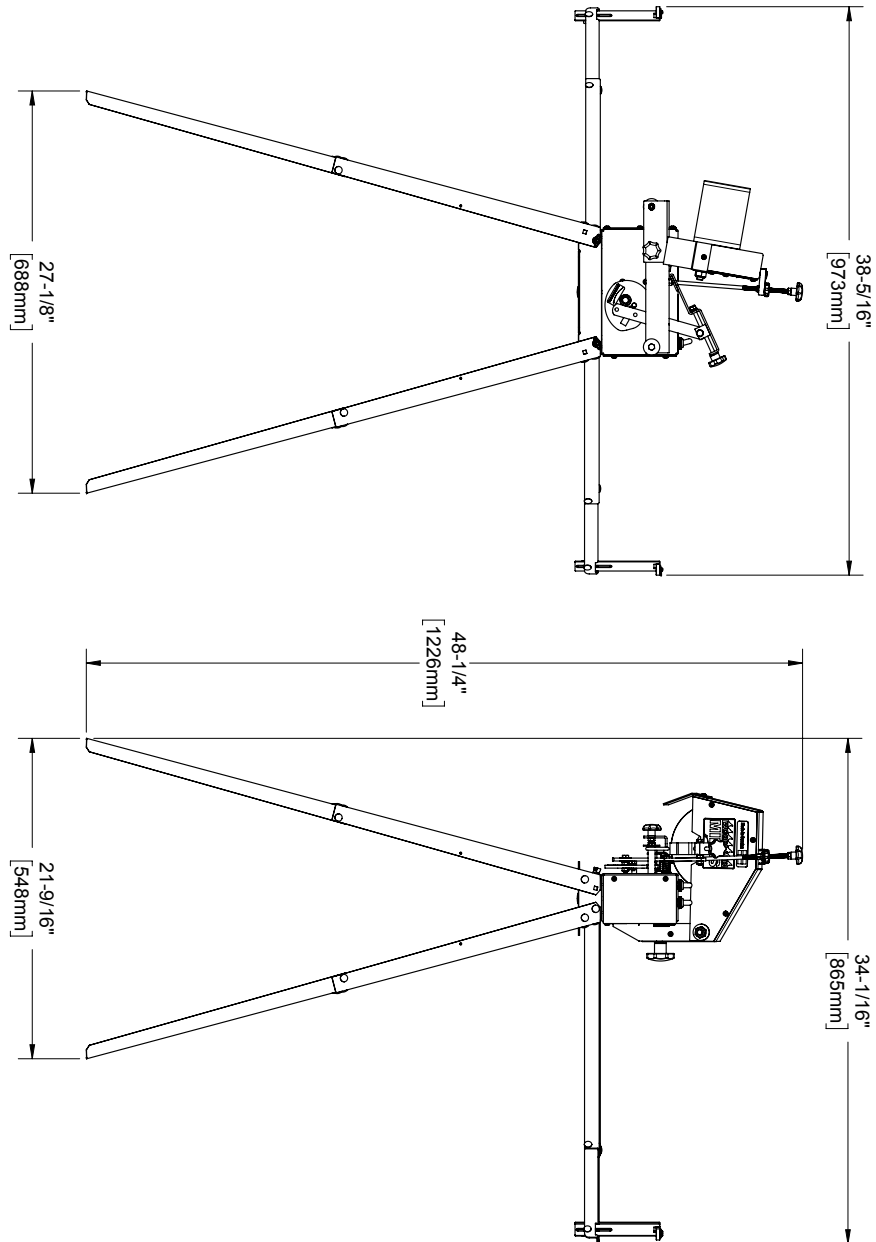

LONGEST SUPPORT ARM POSITION

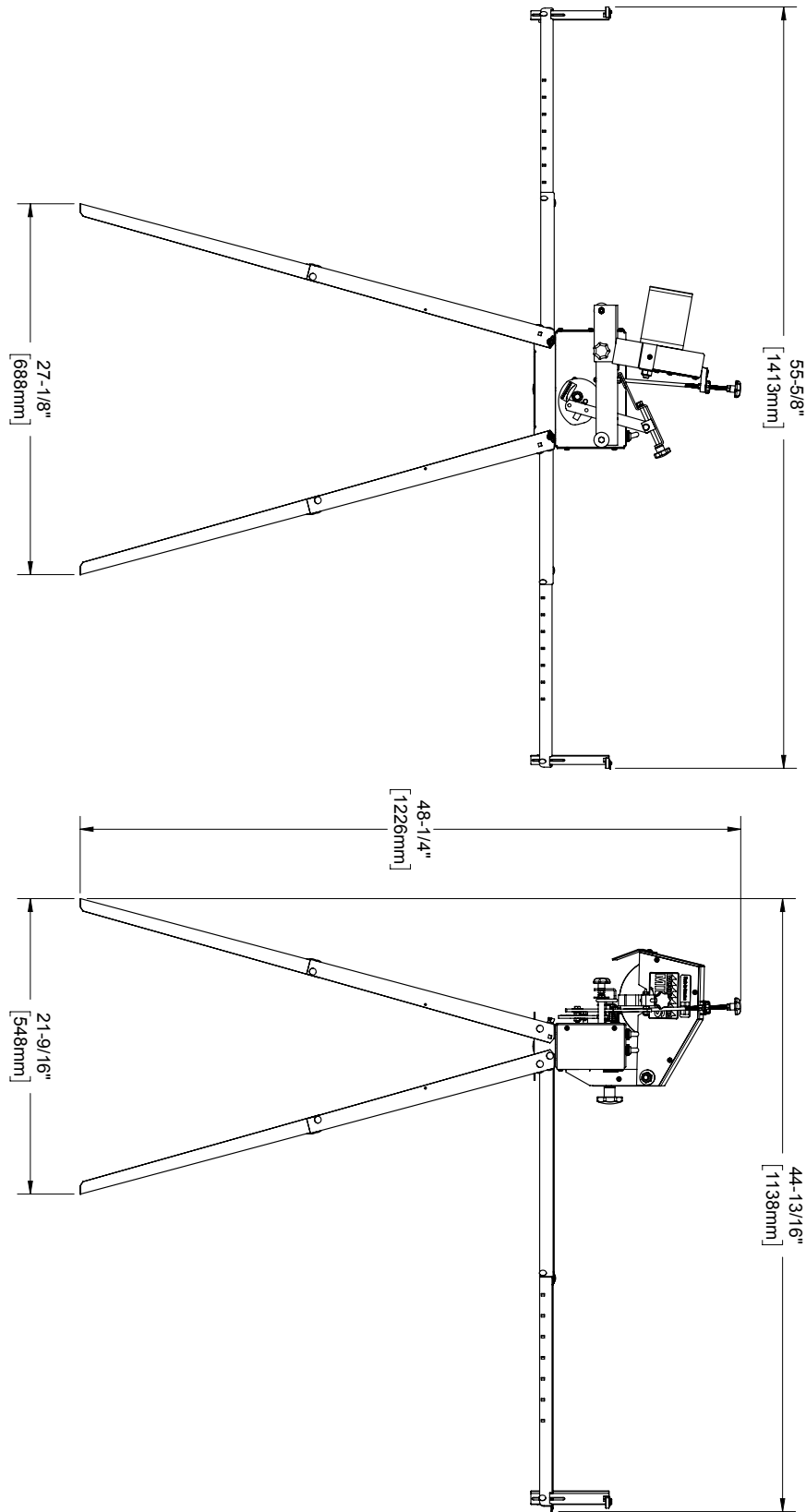

COMPONENT LISTS

Verify all component and hardware quantities are correct prior to assembling the sharpener.

4x	Upper Leg [0001557]		1x	Grinding Shield [0001562]	
4x	Lower Leg [0001558]		1x	M10 Multi-Lobe Knob [0003984]	
1x	Mounting Base [0001554]		1x	M6 4-Lobe Knob [0003980]	
1x	Control Box Assembly		2x	Inner Support Arm [0004159]	
1x	Advancer Assembly		2x	Adjustable Outer Arm Support [0004158]	
1x	Grinding Head Assembly		2x	Blade Support [0001907]	
1x	Grinding Disc [0001553]		2x	Cotter Pin [0004752]	
1x	Depth Adjustment Rod Assembly		2x	Bearing [626-2RS]	
1x	M6 Thru Hole Lock Knob [0003982]		1x	Grinding Disc Profiling Template [0001561]	
1x	M6 Threaded Knob [0003981]		1x	Whetstone [0003132]	

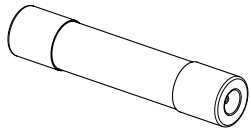
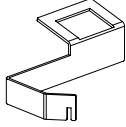
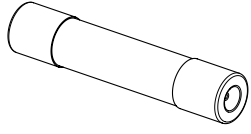

2x	0.5 Amp Fuse* [0003807]		1x	Auto Stop [0001560]	
2x	15 Amp Fuse* [0003808]				

*** 1x 0.5 Amp Fuse and 1x 15 Amp Fuse come installed in the Control Box Assembly**

TO-SCALE HARDWARE

BOLTS & SCREWS

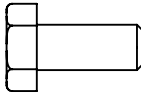
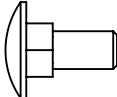
Hardware graphics are printed at 1:1 scale for ease of identification. Simply place the hardware over the image in the tables to verify it is the correct size.

3x	HHB-MBE067FCJ	M6 X 1 X 14 mm HEX BOLT	
26x	SNC-MBA063FCJ	M5 X 0.8 X 12 mm CARRIAGE BOLT	
1x	TST-UAY011FTB	No. 8 X 3/8 in SELF-TAPPING PAN HEAD SCREW	

SCALES

Ruler scales are also provided below to double-check bolt and screw lengths when necessary.



CENTIMETRES / MILLIMETRES



INCHES

WASHERS

26x	FTW-MBE000AJ M6 FLAT WASHER

1x	FTW-MBM000AJ M10 FLAT WASHER

NUTS

20x	HXN-MBACH M5 X 0.8 HEX NUT

2x	HXN-MBECH M6 X 1 HEX NUT

2x	HLN-MBACH M5 X 0.8 LOCK NUT

4x	0006216 M5 X 0.8 WING NUT

ASSEMBLY



1. TOOLS REQUIRED

Tool	Specification
Screwdriver	T20 Torx
Wrench/Socket	8 mm
Wrench/Socket	10 mm
Pliers	Min. 2 in [50 mm] grip dia

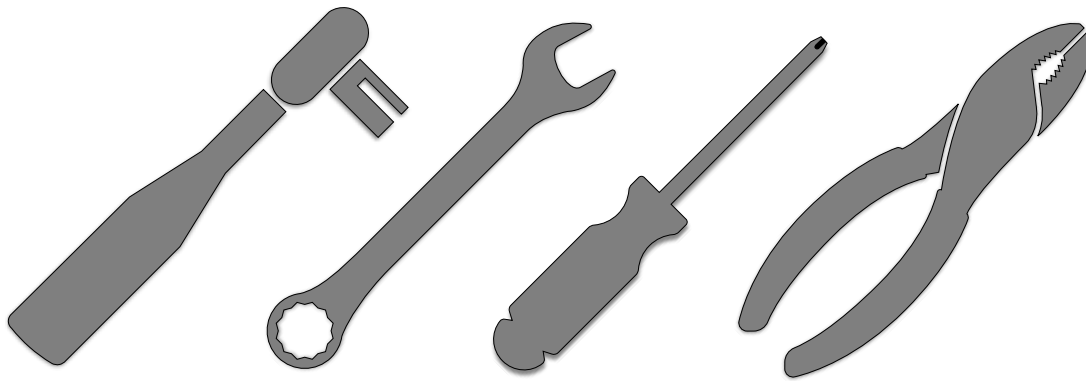

2. MOUNTING STYLE

Before starting the assembly, decide how the sharpener will be mounted when in use. If utilizing the stand is desirable from a portability standpoint, proceed to the next section, **STAND**.

However, if the sharpener would be better utilized secured to a workbench, skip over the **STAND** section and start at assembly step, **CONTROL BOX**.

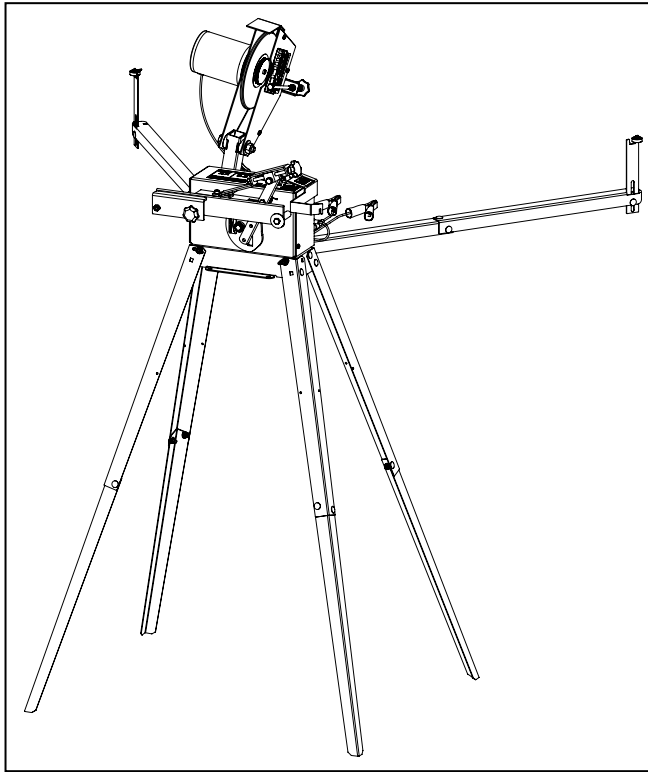

STAND MOUNT

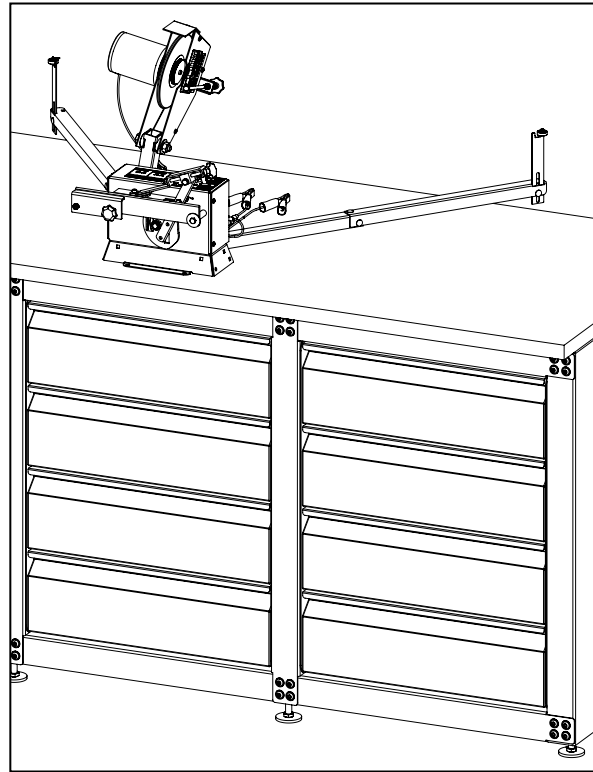

WORKBENCH MOUNT

****Note: The graphics in the manual assume a stand-mount installation but the instructions will note the assembly differences where applicable.****

3. STAND

Using the hardware and components listed below, assemble the stand. If the sharpener will be mounted directly to a workbench, skip this assembly step and proceed to the next **section**.

16x	M5 X 12 mm Carriage Bolt		16x	M6 Flat Washer	
16x	M5 Hex Nut		4x	Upper Leg	
16x	M5 Lock Nut		4x	Lower Leg	
2x	M5 Wing Nut		1x	Mounting Base	

A. LEGS

Assemble the lower leg to the upper leg using two (2) M5 X 12 mm carriage bolts, two (2) M6 flat washers, and two (2) M5 hex nuts. Repeat this for all four (4) legs.

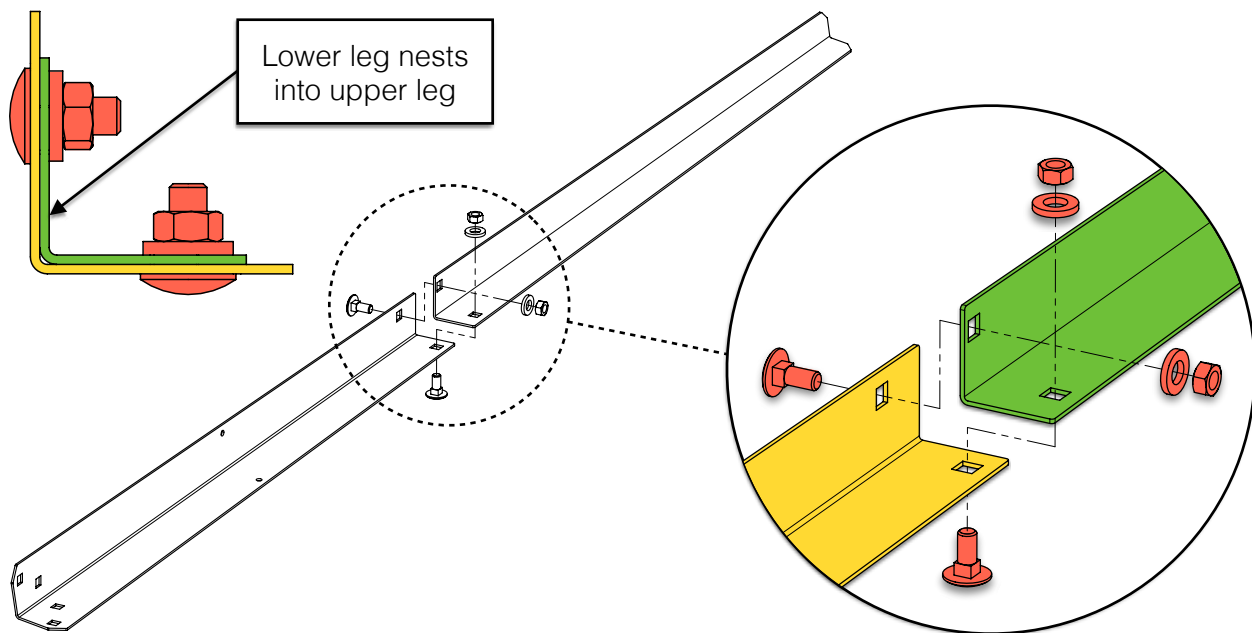

B. LEGS-TO-MOUNTING BASE (FRONT)

With all the legs assembled, fasten the front legs to the mounting base using the following hardware on each leg: two (2) M5 X 12 mm carriage bolts, two (2) M6 flat washers, one (1) M5 lock nut, and one (1) M5 wing nut.

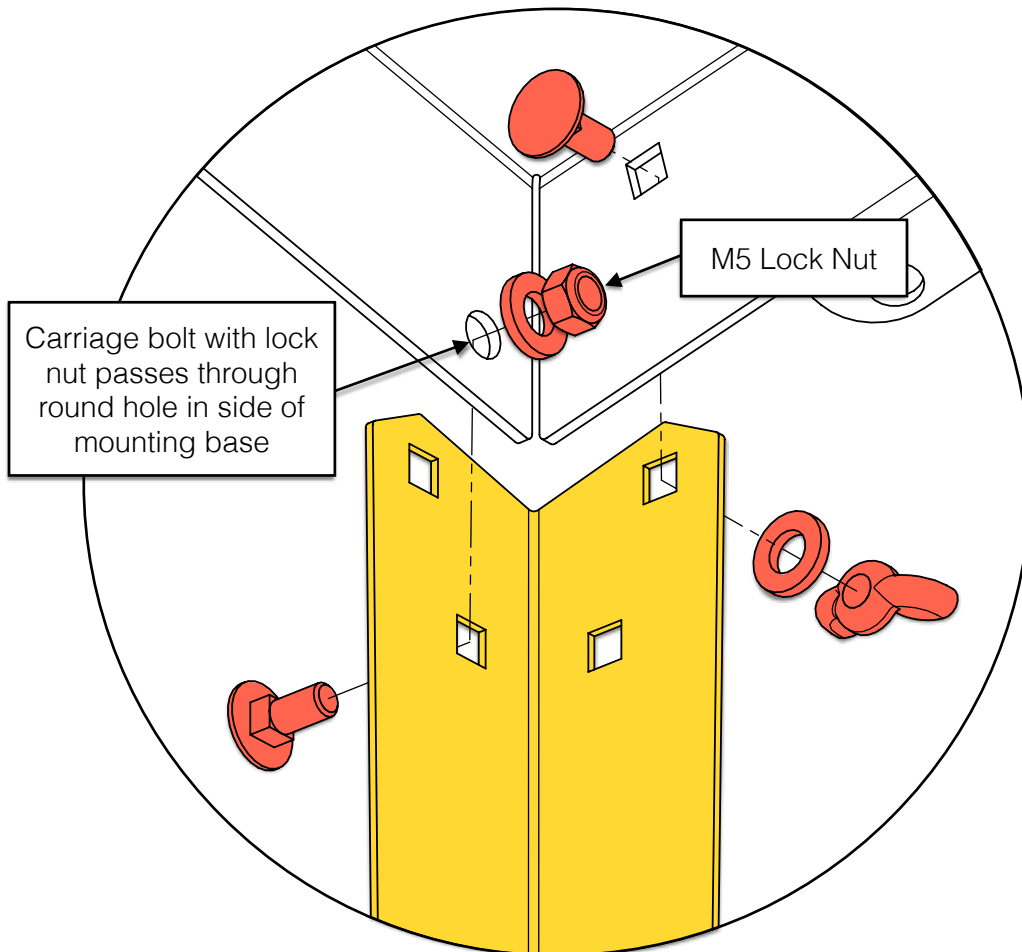
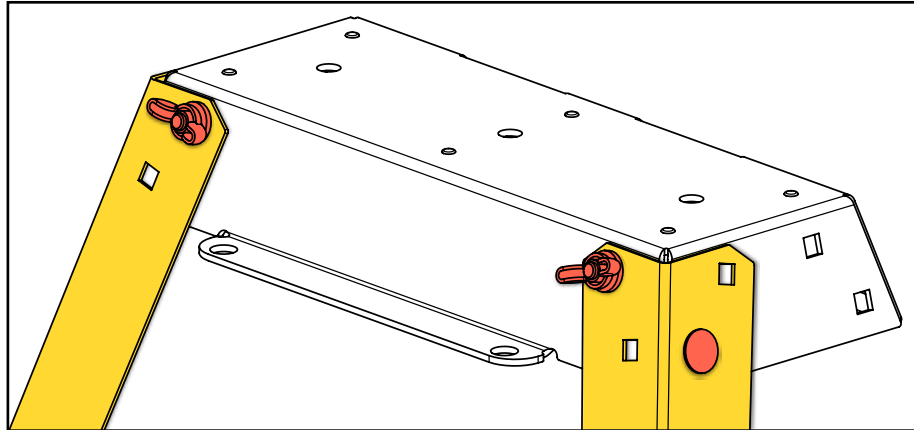

C. LEGS-TO-MOUNTING BASE (REAR)

Fasten the rear legs to the mounting base using the following hardware on each leg: four (4) M5 X 12 mm carriage bolts, four (4) M6 flat washers, four (4) M5 hex nuts.

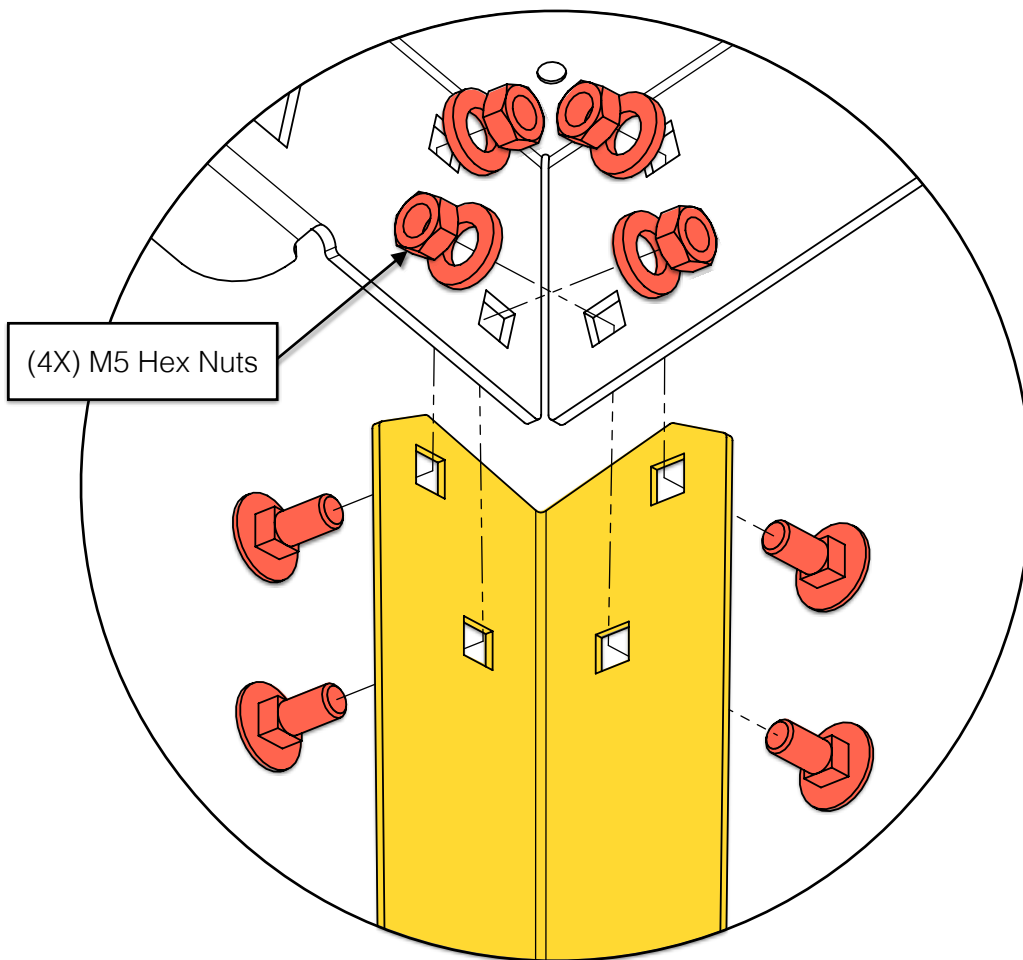
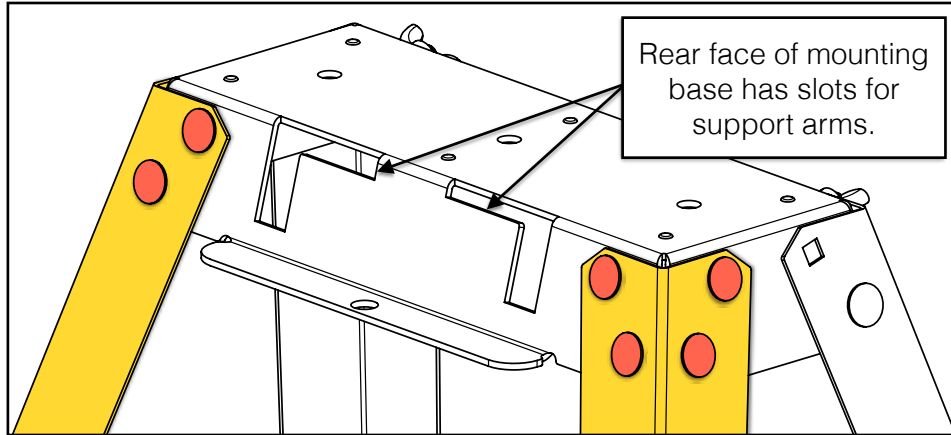

The completed stand should now look as shown:

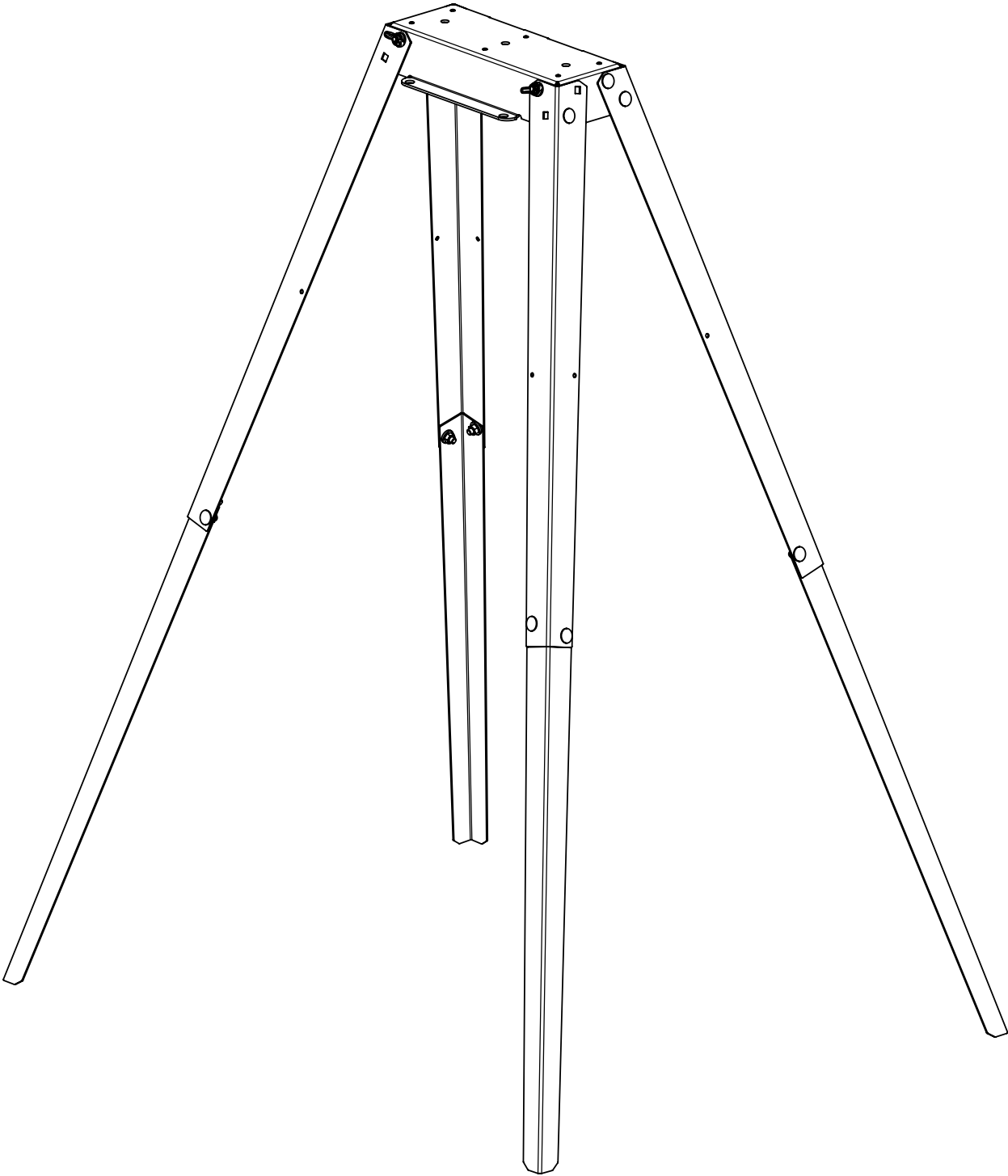

4. CONTROL BOX

Using the hardware and components listed below, assemble the control box to the stand and the advancer to the control box.

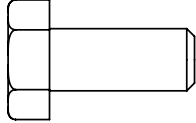
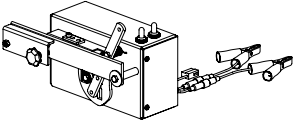
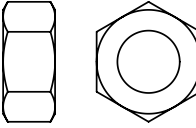
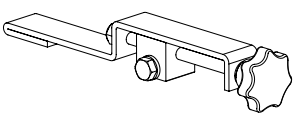
2x	M6 X 14 mm Hex Bolt		1x	Control Box Assembly	
1x	M6 Hex Nut		1x	Advancer Assembly	

A. CONTROL BOX-TO-STAND

Assemble the control box to the stand using the two (2) M6 X 14 mm hex bolts as shown.

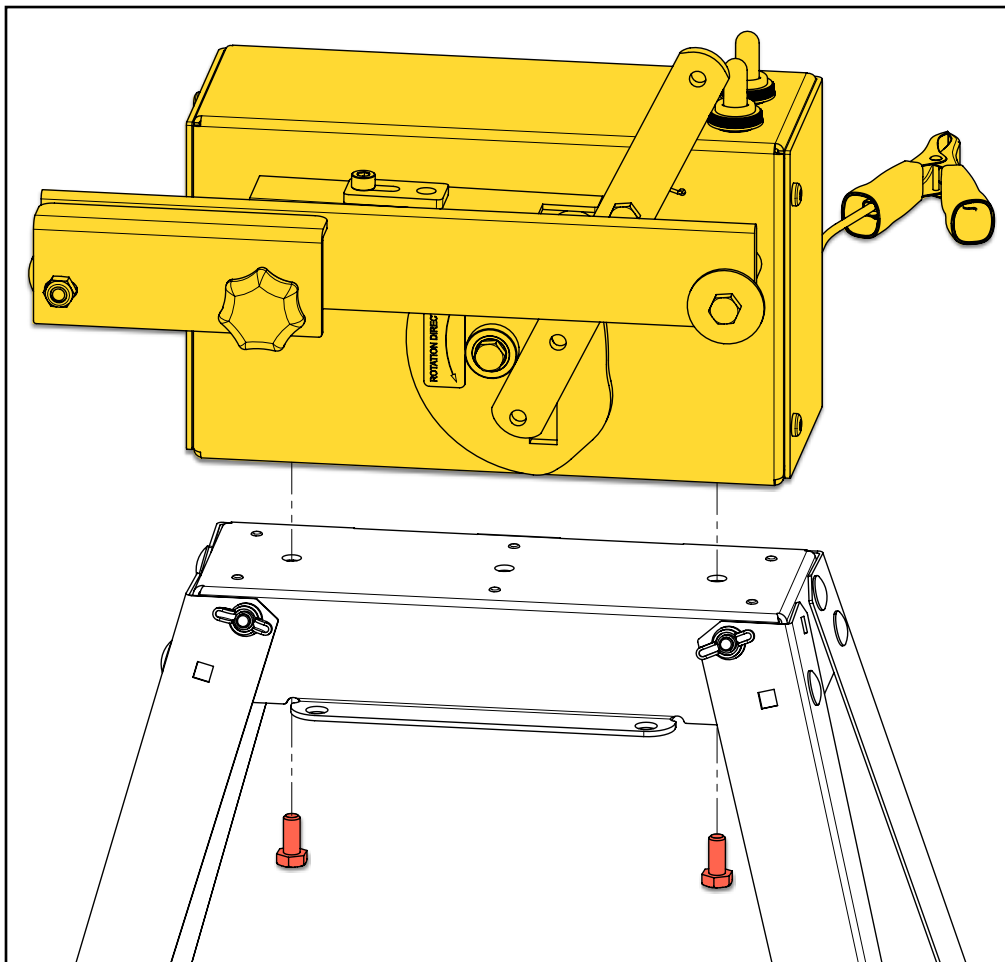

B. ADVANCER

Assemble the advancer assembly to the connecting arm on the control box using one (1) M6 hex nut (a second M6 hex nut comes assembled to the advancer).

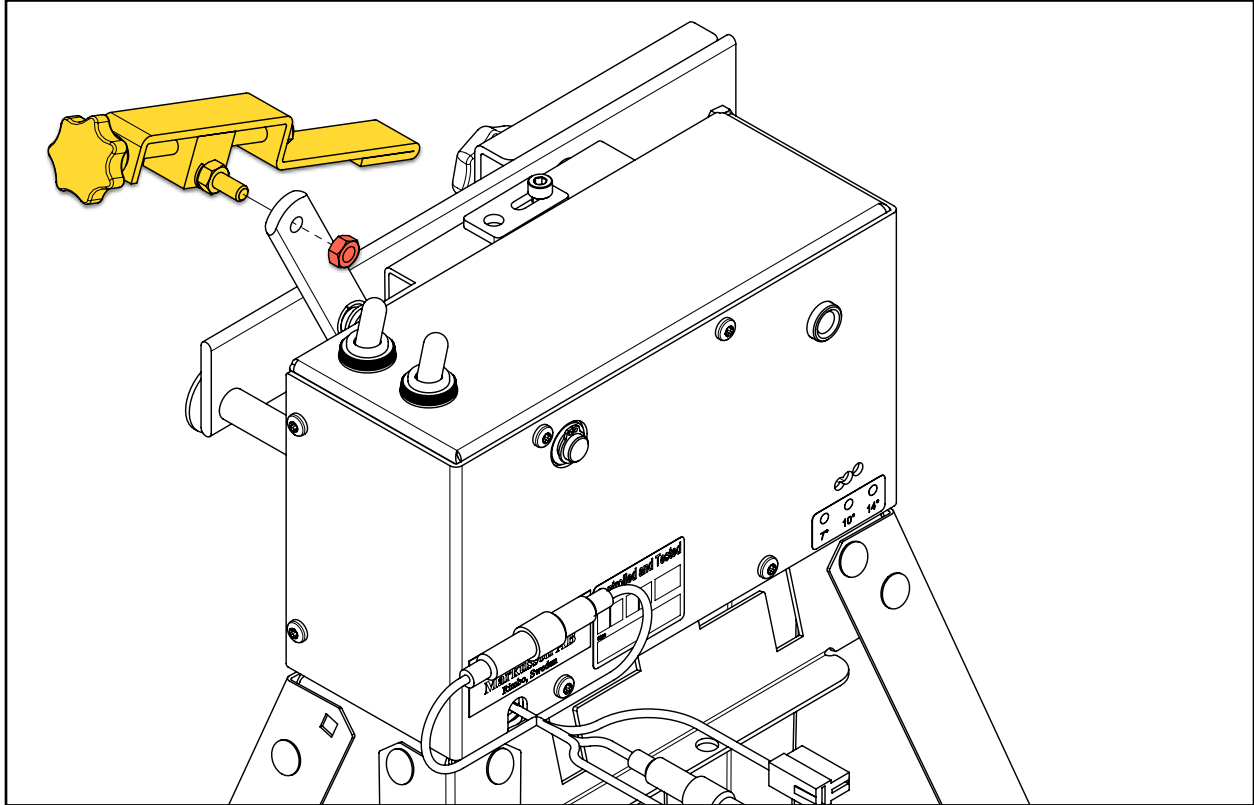

Fully tighten both M6 hex nuts to the connecting arm on the control box. It is important that while this connection is tight, the advancer still pivots freely about the bolt passing through it.

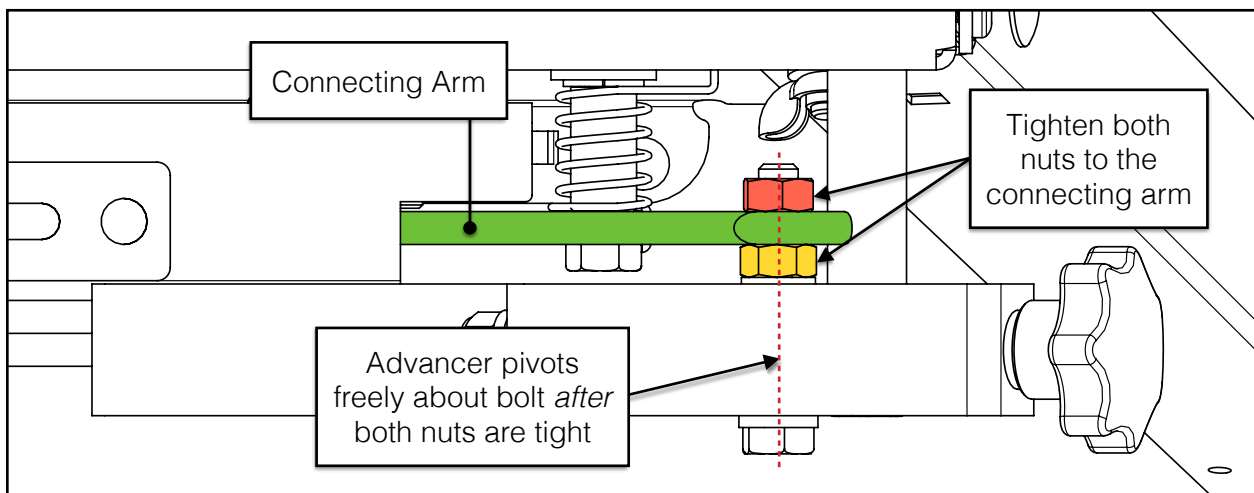

5. GRINDING HEAD

Begin the grinding head assembly by using the hardware listed below to assemble the grinding head assembly to the control box.

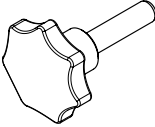
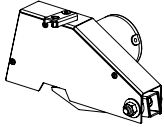
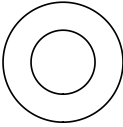
1x	M10 X 40 mm Knob		1x	Grinding Head Assembly	
1x	M10 Flat Washer				

A. GRINDING HEAD-TO-CONTROL BOX

Assemble the grinding head to the rear of the control box using the M10 X 40 mm knob and M10 flat washer. Then connect the motor cable to the wiring harness.

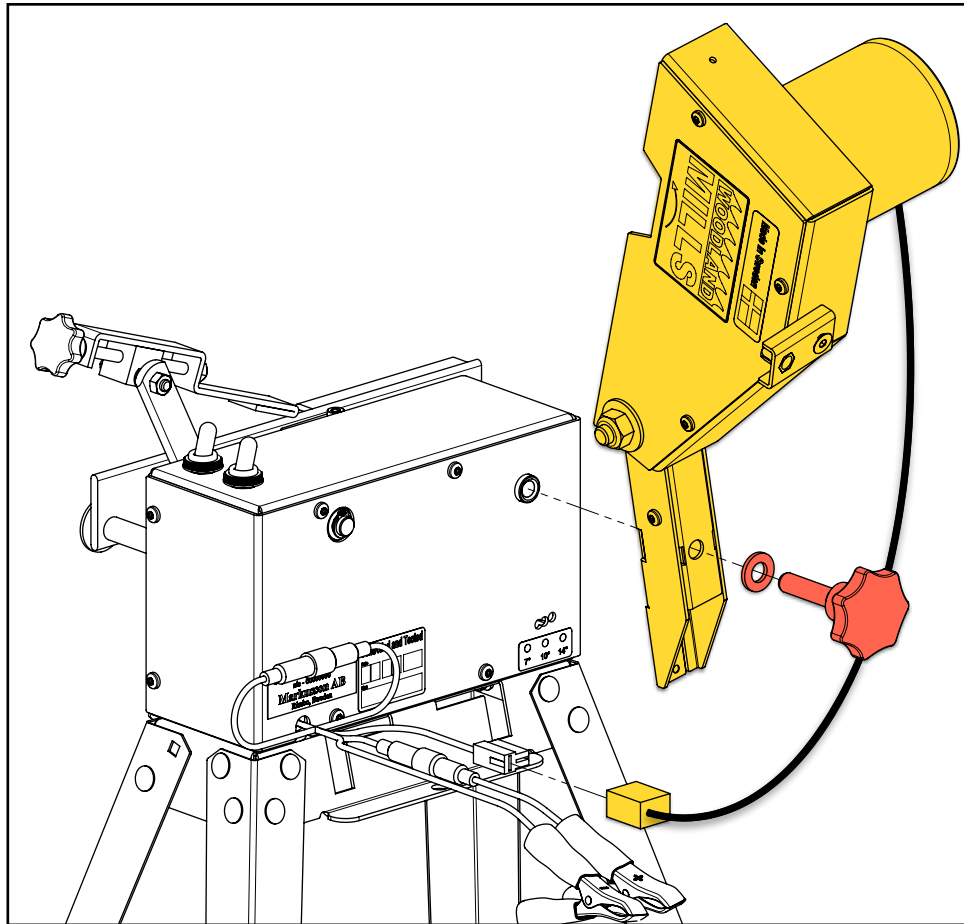

B. GRINDING DISC

Next, assembly the grinding disc to the grinding head assembly.

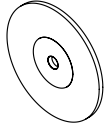
1x	Grinding Disc	
----	---------------	---

Remove the knurled nut from the electric motor and slide the grinding disc onto the shaft. Replace the nut and tighten it securely using pliers.

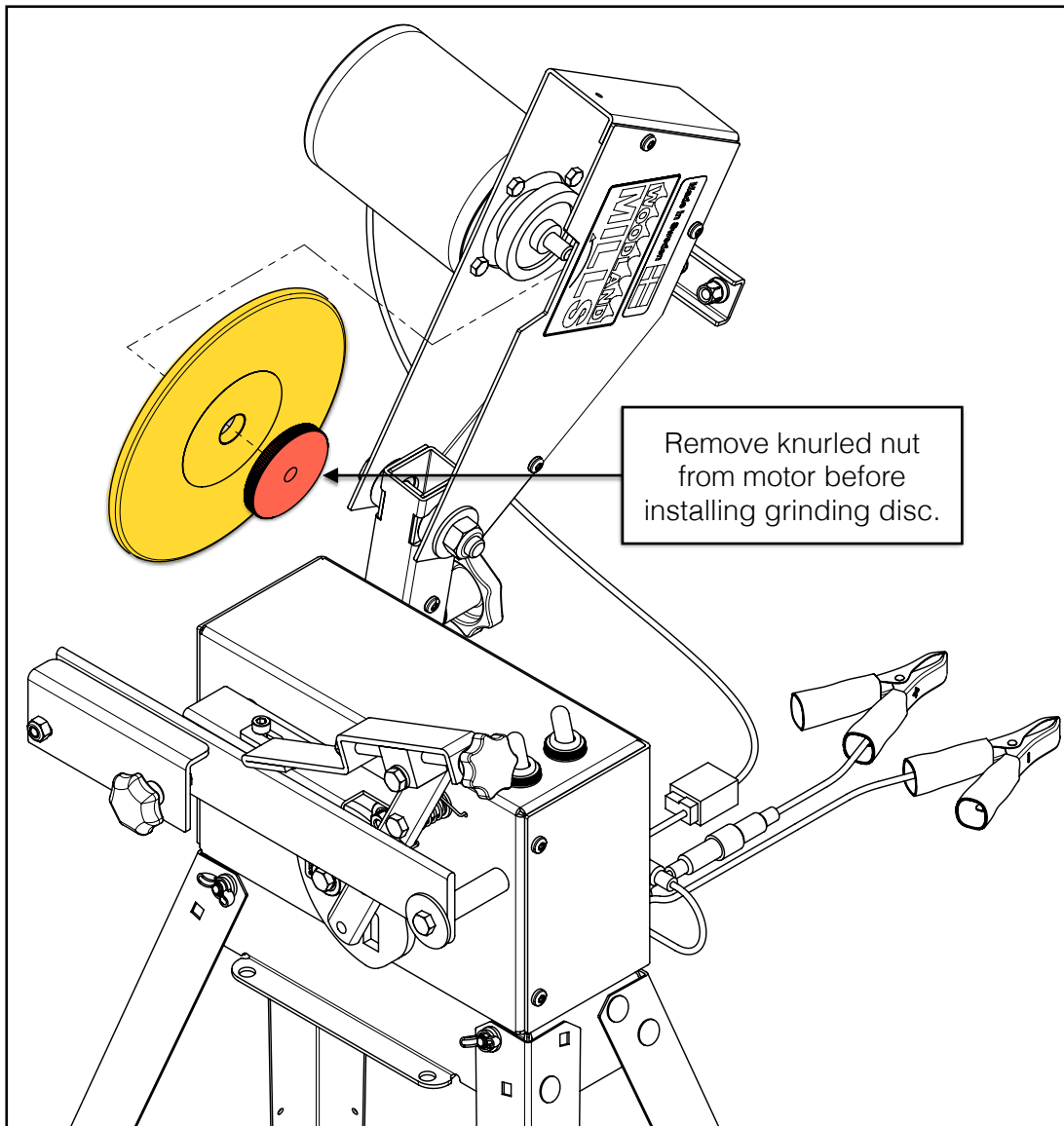

C. DEPTH ADJUSTMENT ROD

Using the hardware listed below, assemble the depth adjustment rod to the grinding head.

1x	M6 Hex Nut		1x	Depth Adjustment Rod	
1x	M6 Acorn Nut		1x	M6 Thru-Hole Lock Knob	
			1x	M6 Threaded Knob	

Thread the long-threaded end of the rod up through the bracket on the grinding head. Then thread the thru-hole lock knob, the M6 hex nut, and the upper knob to the top of the rod. Finally, thread the acorn nut onto the bottom end of the rod. Ensure the distance from the top of the bracket to the tip of the acorn nut is approx. 7 in [178 mm] for ease of adjustment later.

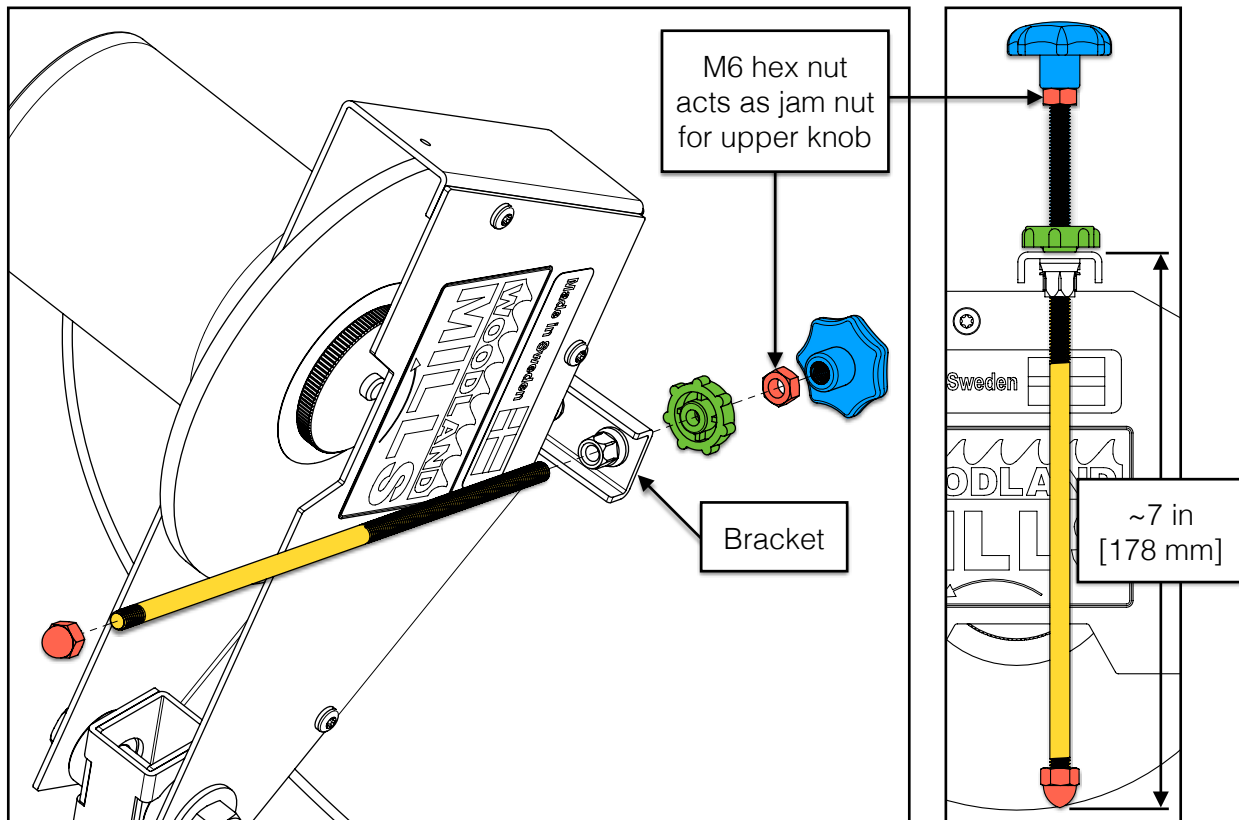

D. GRINDING SHIELD

To finalize the grinding head assembly, secure the grinding shield to the grinding head using the hardware listed below.

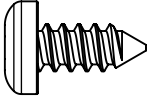
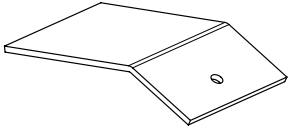
1x	#8 X 0.375 Torx Self-Tapping Screw		1x	Grinding Shield	
----	---------------------------------------	---	----	-----------------	---

Using a T20 Torx screwdriver, secure the shield to the grinding head as shown.

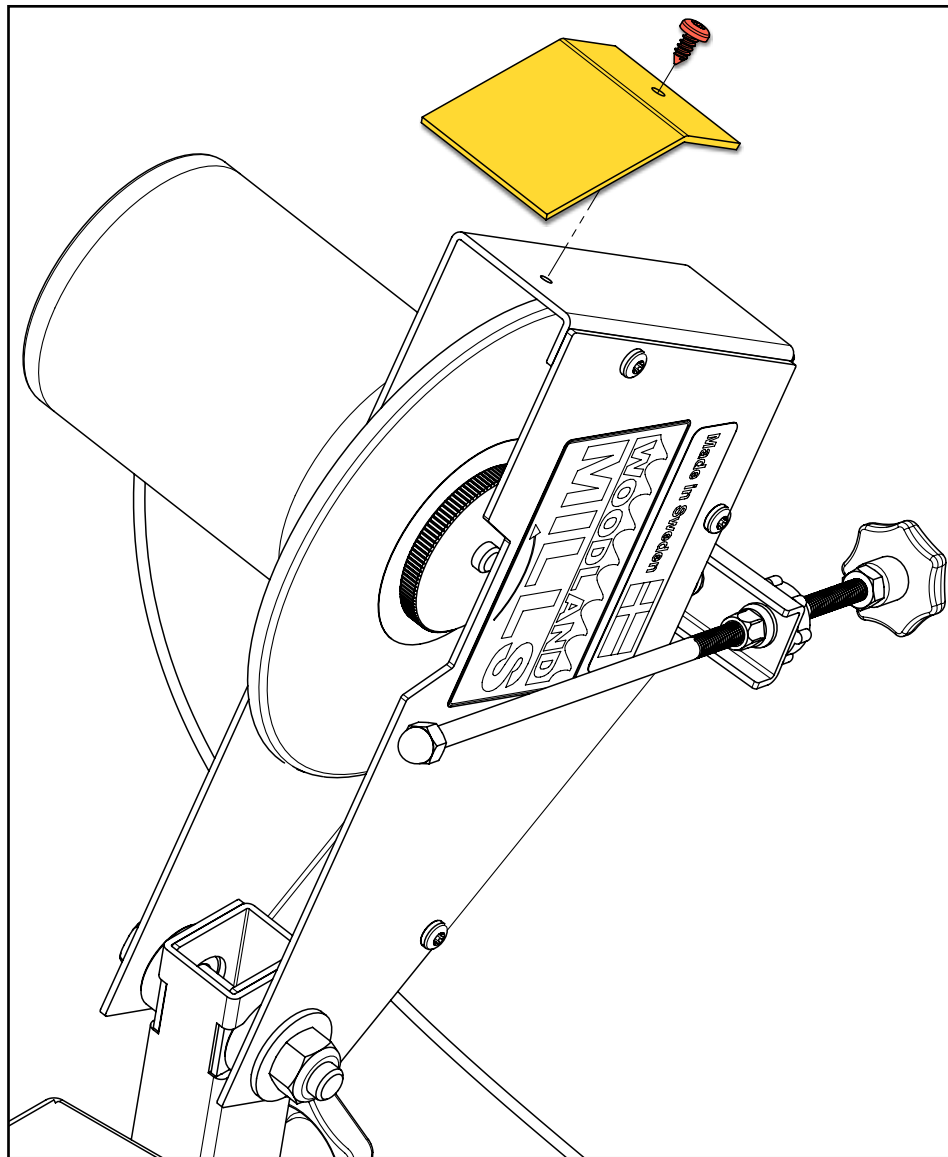

6. SUPPORT ARMS

A. INNER SUPPORT ARMS

Using the hardware and components listed below, assemble the inner support arms to the sharpener.

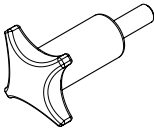
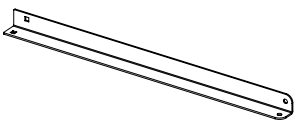
1x	M6 4-Lobe Knob		2x	Inner Support Arm	
----	----------------	---	----	-------------------	---

Facing the rear of the sharpener, slide the right inner support arm into the cutout in the mounting base. Then slide the left support arm into the other cutout ensuring the left arm is below the right arm. Secure both arms to the base and control box using the M6 4-lobe knob.

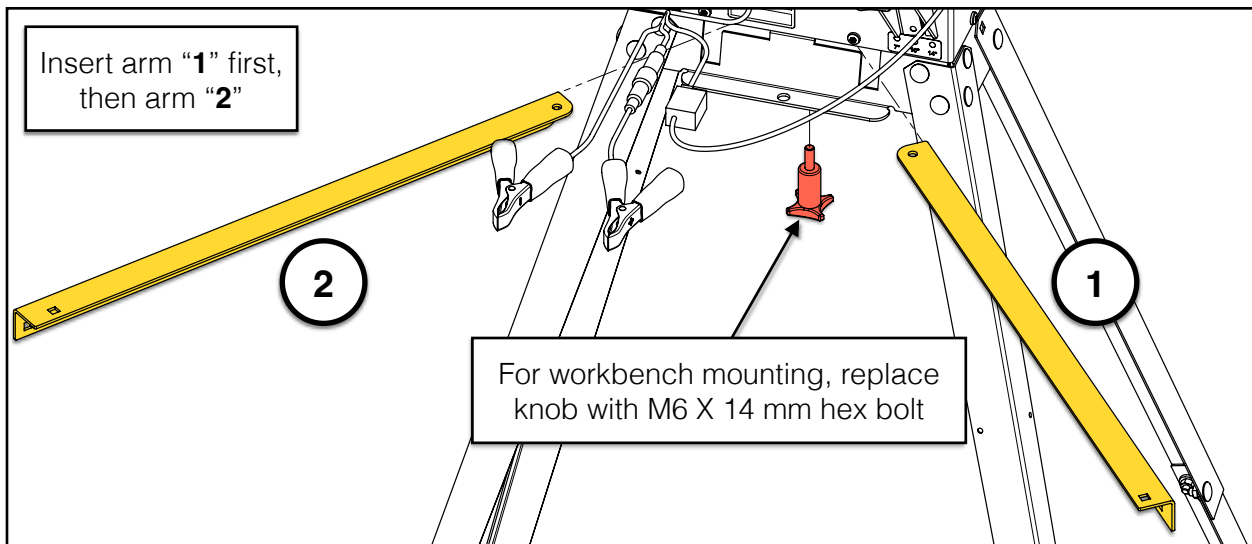

Note: If mounting the sharpener to a workbench, fasten the inner support arms to the mounting base using the extra M6 X 14 mm hex bolt instead of the M6 4-lobe knob. See section, **WORKBENCH MOUNTING**, for more information.

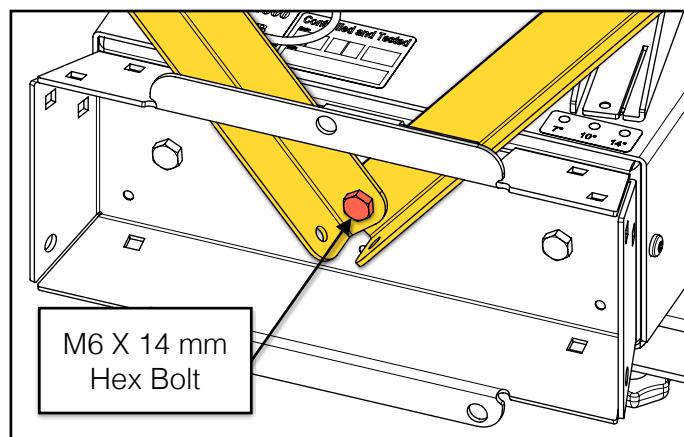

WORKBENCH MOUNTING ONLY

B. ADJUSTABLE OUTER SUPPORT ARMS

Using the hardware and components listed below, assemble the adjustable outer support arms to the sharpener.

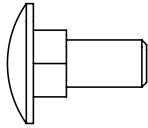
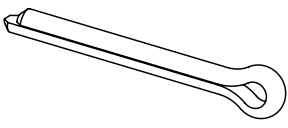
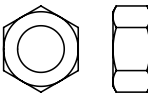
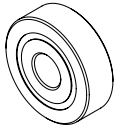
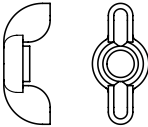
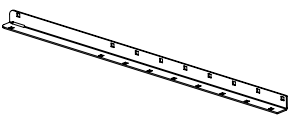
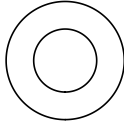
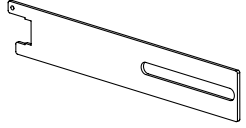
6X	M5 X 12 mm Carriage Bolt		2x	Cotter Pin	
4X	M5 Hex Nut		2x	626-2RS Bearing	
2x	M5 Wing Nut		2x	Adjustable Outer Support Arm	
8X	M6 Flat Washer		2x	Blade Support	

Assemble an outer support arm to both of the inner support arms using two (2) carriage bolts, two (2) M6 flat washers, and two (2) M5 hex nuts. Slide the blade support through the slots in the ends of the outer supports and secure them with a carriage bolt, flat washer, and wing nut.

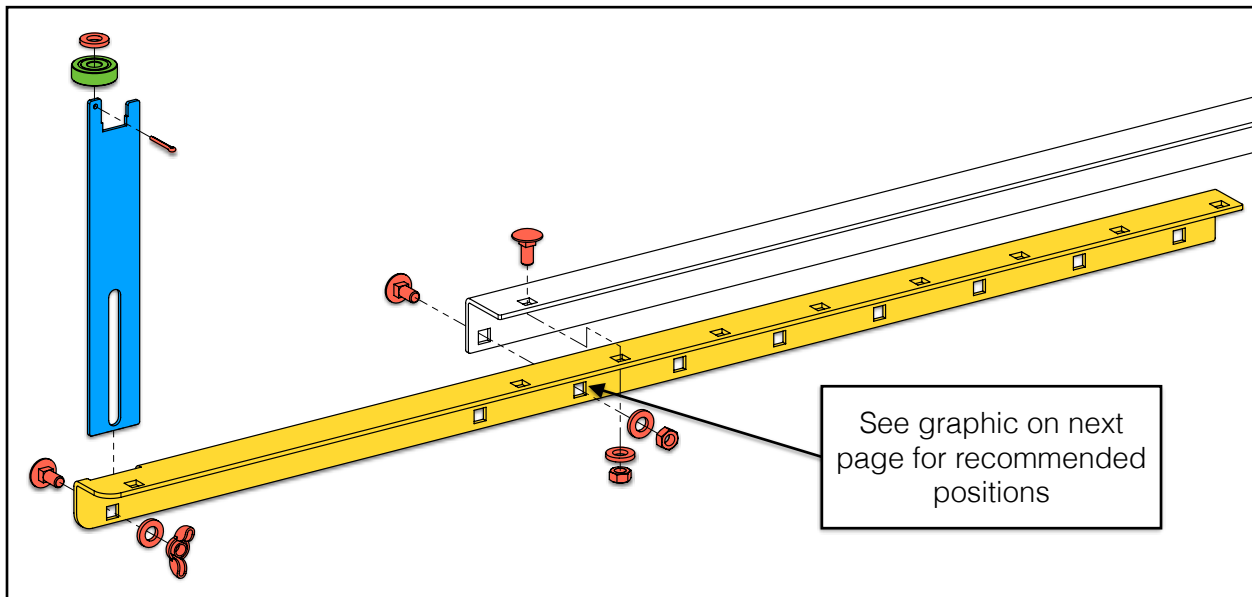

The adjustable outer support arms each contain eight (8) square holes—spaced 2 in [50 mm] apart—that allow the sharpener to accommodate a wide range of blade lengths.

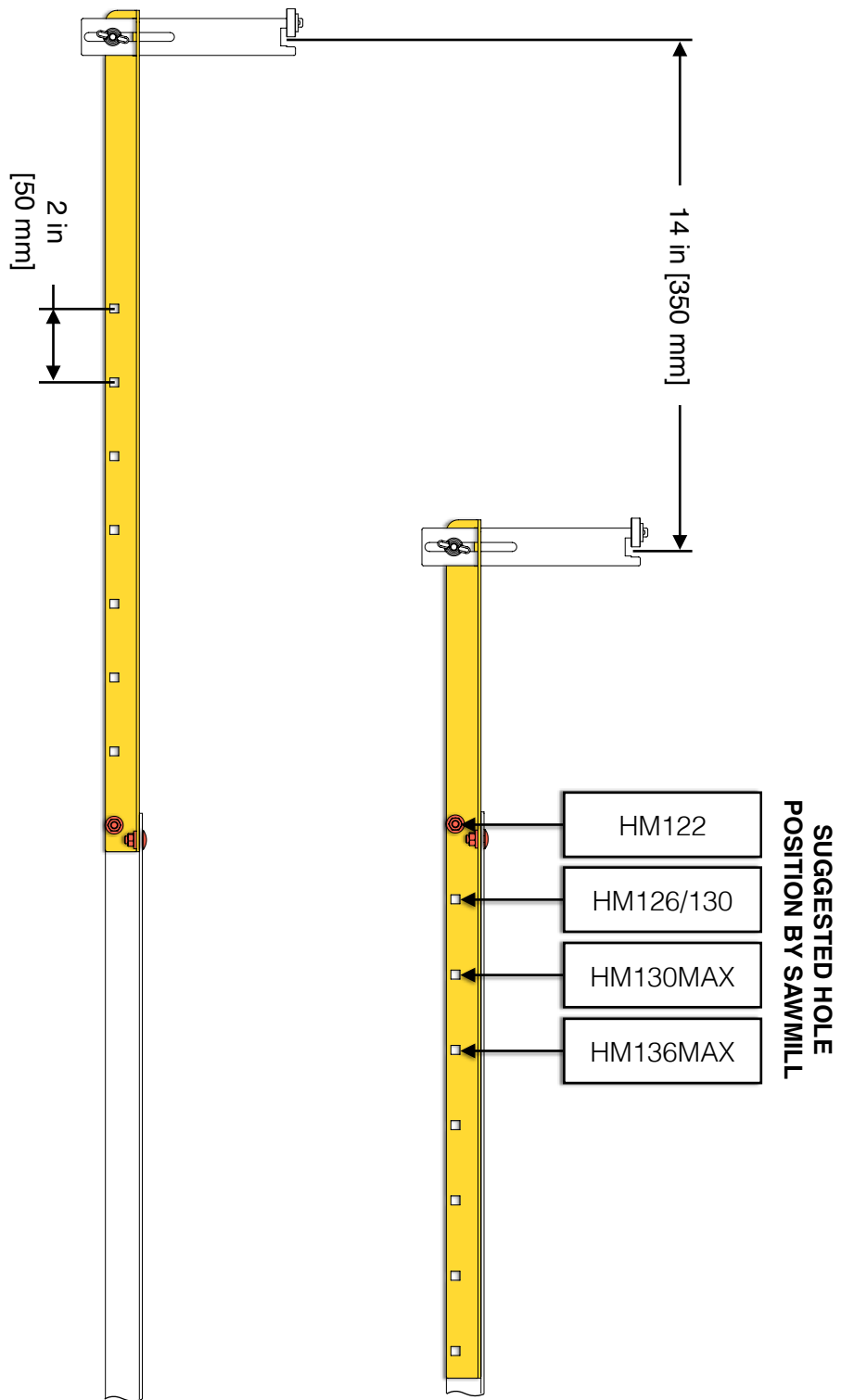

7. WORKBENCH MOUNTING (OPTIONAL)

If it is desirable to mount the sharpener to a workbench instead of utilizing the stand, be sure the M6 X 14 mm hex bolt was used in place of the the 4-lobe knob in step, ***INNER SUPPORT ARMS***, on page 23.

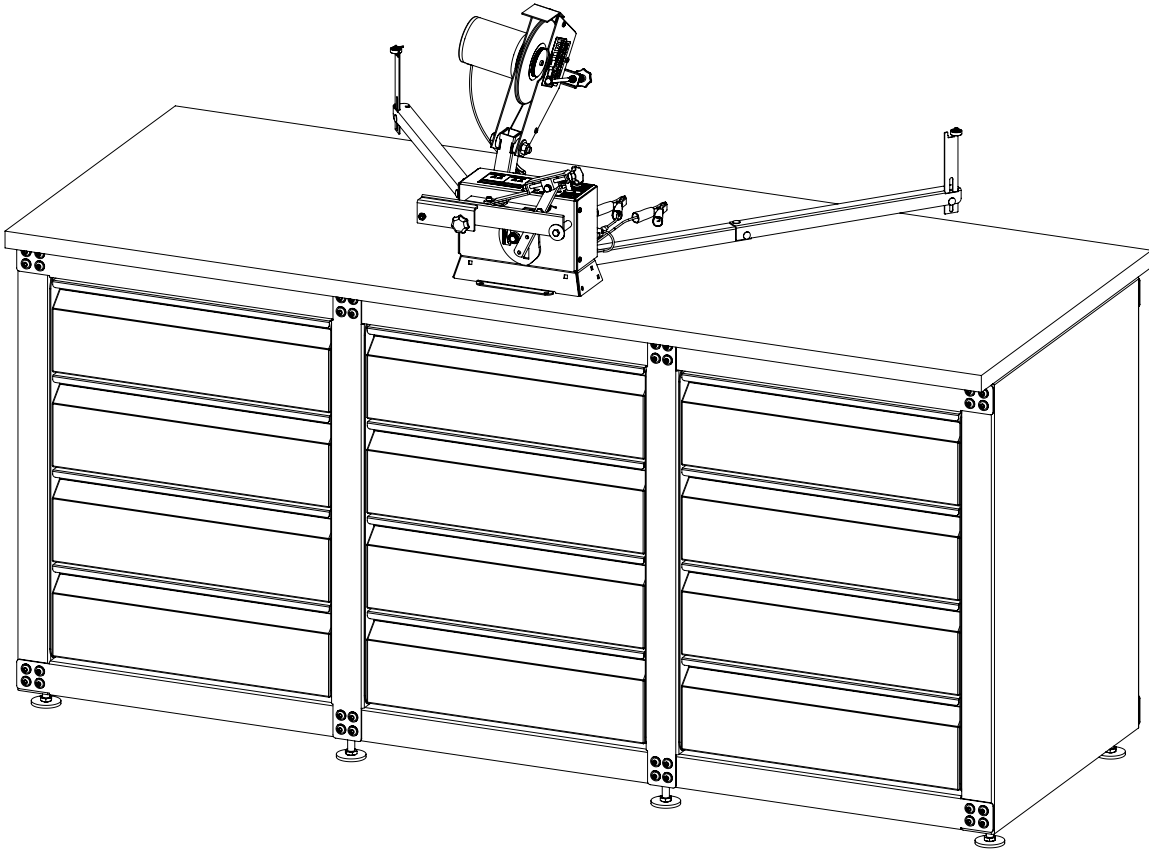

No workbench-mounting hardware is included with the sharpener and must be provided by the customer. The mounting holes will accept hardware no larger than 5/16 in [8 mm].

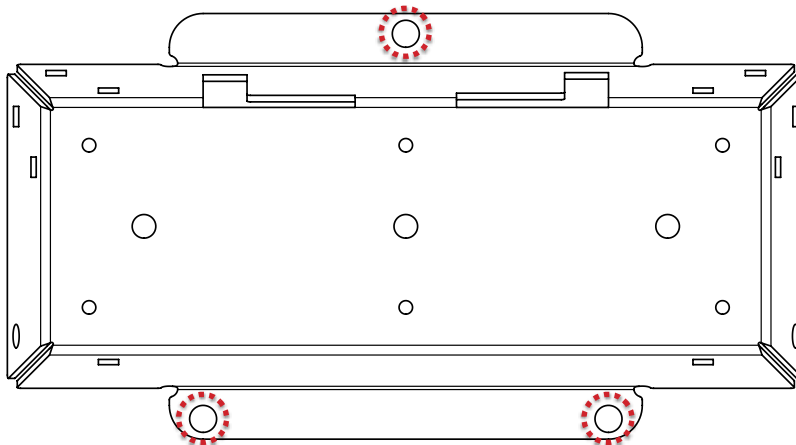

BATTERY

The customer is required to purchase their own 12 Volt battery.

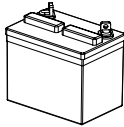
1x	12 V Battery	
----	--------------	---

Follow the battery polarity label on top of the control box: connect the **POSITIVE** clamp (+ red) to the positive battery terminal and the **NEGATIVE** clamp (– black) to the negative battery terminal.

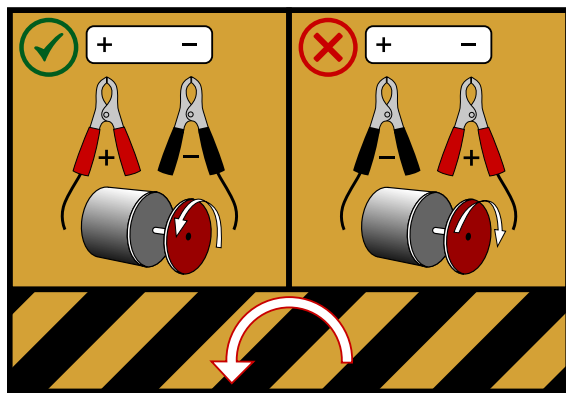

BATTERY POLARITY LABEL

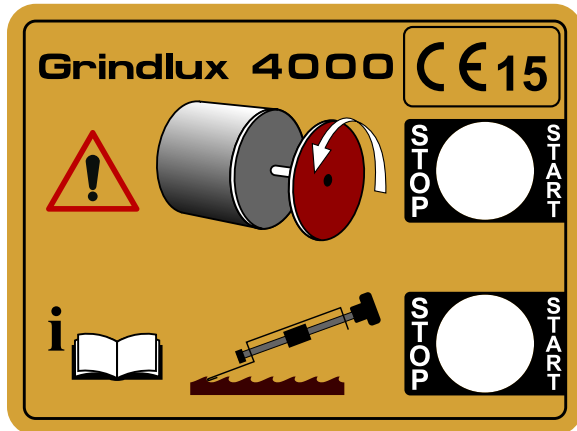

TOGGLE SWITCH LABEL

****Always remember to check that the toggle switches are in the STOP position before connecting the battery.****

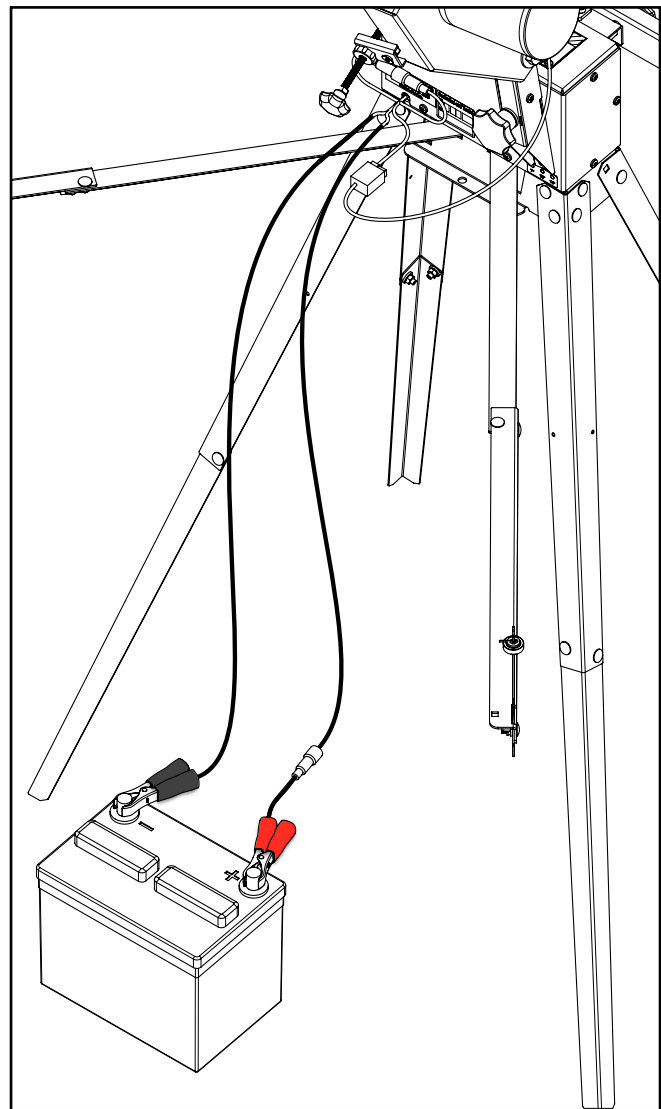

MAINTENANCE

The bandsaw blade should be set and sharpened regularly for optimal performance. During normal sawing of most wood species this should be done at intervals of approximately 2 hours of effective cutting time (*effective cutting time* refers to the time the bandsaw blade was actually cutting). The bandsaw blade should be sharpened more frequently when cutting those species of wood with a high sand content.

CLEANING AND INSPECTION



Clean sawdust and any coating from the bandsaw blade.

Check whether there are cracks in the gullets (**FIG 1**). Small cracks can be ground away when sharpening the blade. If the cracks are so large that they cannot be ground away, the bandsaw blade should be discarded.

Cracks in the gullets “**G**” are the most common cause of bandsaw blade breakage.

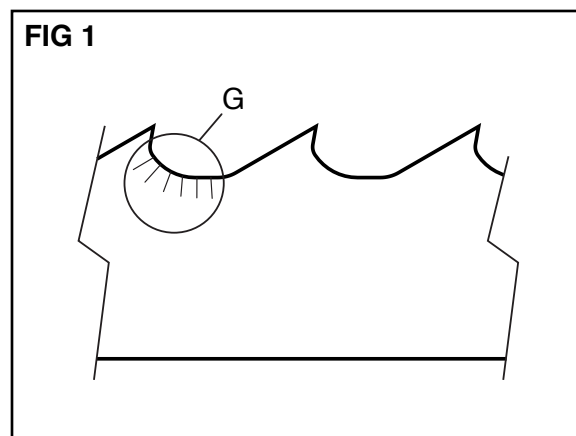

WARNING!

The bandsaw blade is sharp and can cause injury. Always wear protective gloves when handling the bandsaw blade.



WARNING!

Never use a damaged bandsaw blade.

SAW BLADE GEOMETRY

Saw blade tooth geometry follows a particular “set” pattern where one tooth is straight (rake tooth), the next is set up, the next is set down, and then a straight rake tooth again. This 4-tooth pattern repeats throughout the entire length of the saw blade.

The example below is illustrative of a typical *Woodland Mills* saw blade.

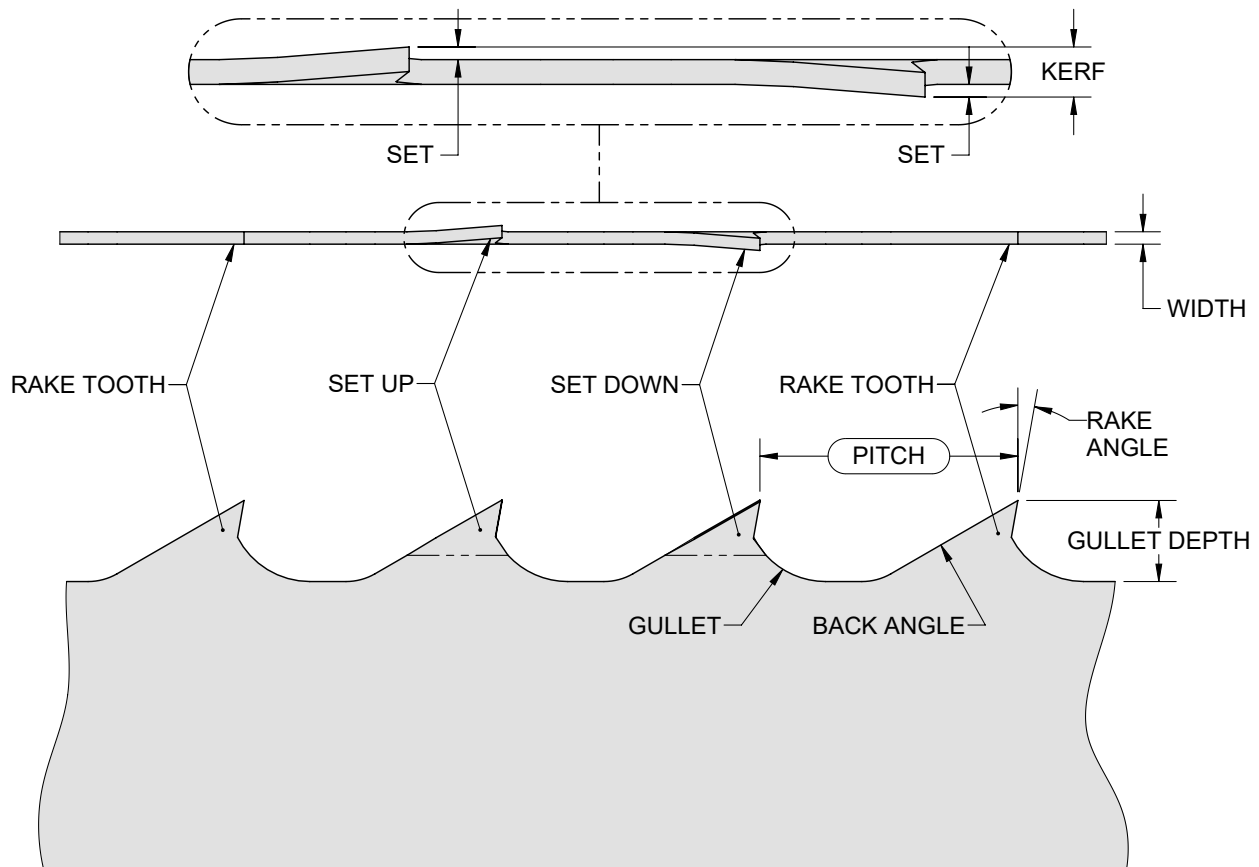

Pitch: The distance between the tips of two adjacent teeth.

TPI: The number of *Teeth Per Inch* on a blade, commonly referred to as **Pitch**. See definition above.

Gullet: The valley between the points of two adjacent teeth.

Gullet Depth: The distance measured from the gullet's lowest point to the tooth tip.

Rake Angle: Also called **Rake** or **Hook Angle**, is the angle of the front face of the tooth perpendicular to the length of the blade.

Back Angle: Also called **Relief Angle**, is the angle down the back side of the tooth.

Rake Tooth: A straight tooth with no set.

Width: The thickness of the blade material without regard to set.

Set: The degree to which the teeth are bent up or down away from the blade.

Kerf: The narrow channel in the wood left behind by the saw, roughly equating to the distance measured across two opposing set teeth.



SHARPENING GUIDELINES

The more accurate the sharpening, the straighter and smoother the bandsaw blade runs when cutting the log.

GULLET RADII

The radius in the gullet area “R” (FIG 2) should be 0.04 to 1/8 in [1 to 3 mm].

A radius under 0.04 in [1 mm] increases the risk of cracking. A radius over 1/8 in [3 mm] means that the chips are not broken.

BACK AND HOOK ANGLES

The back angle is normally between 10-12° (FIG 3) and the hook angle “A” (FIG 4) varies depending on the species of wood as shown in the table below:

Hardwoods/Frozen Timber	7°
General	10°
Softwoods	14°



WARNING!
The bandsaw blade is sharp and can cause injury. Always wear protective gloves when handling the bandsaw blade.

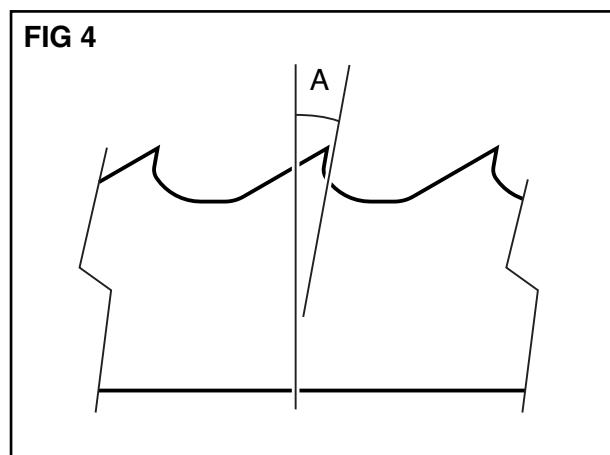
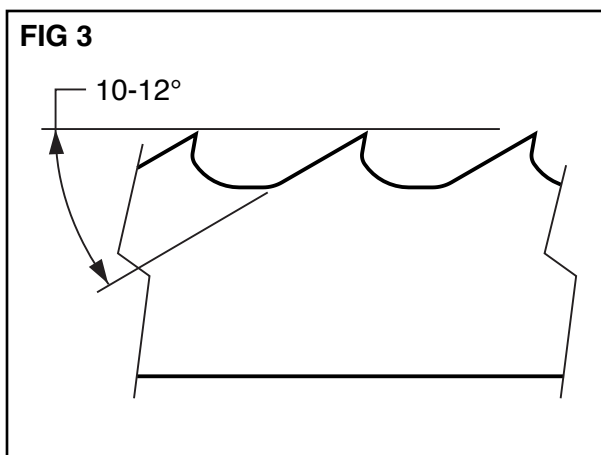
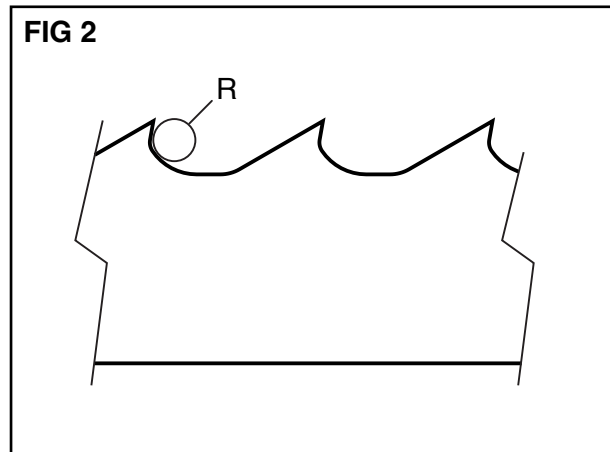

PROFILING THE GRINDING DISC

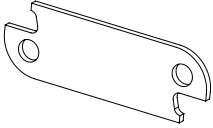
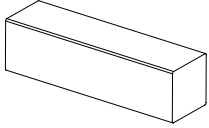

The grinding disc must have the correct profile *prior* to sharpening a blade. Use the grinding disc profile template and whetstone shown in the table below to shape the disc.

1x	Grinding Disc Profiling Template		1x	Whetstone	
----	----------------------------------	---	----	-----------	---

****Note: do not shape the grinding disc using the profiling template. The profiling template is only used to check the disc profile after it has been shaped using the whetstone.****

Connect the sharpener to a 12 V battery. Then flip the grinding head all the way up and start the motor using the toggle switch.

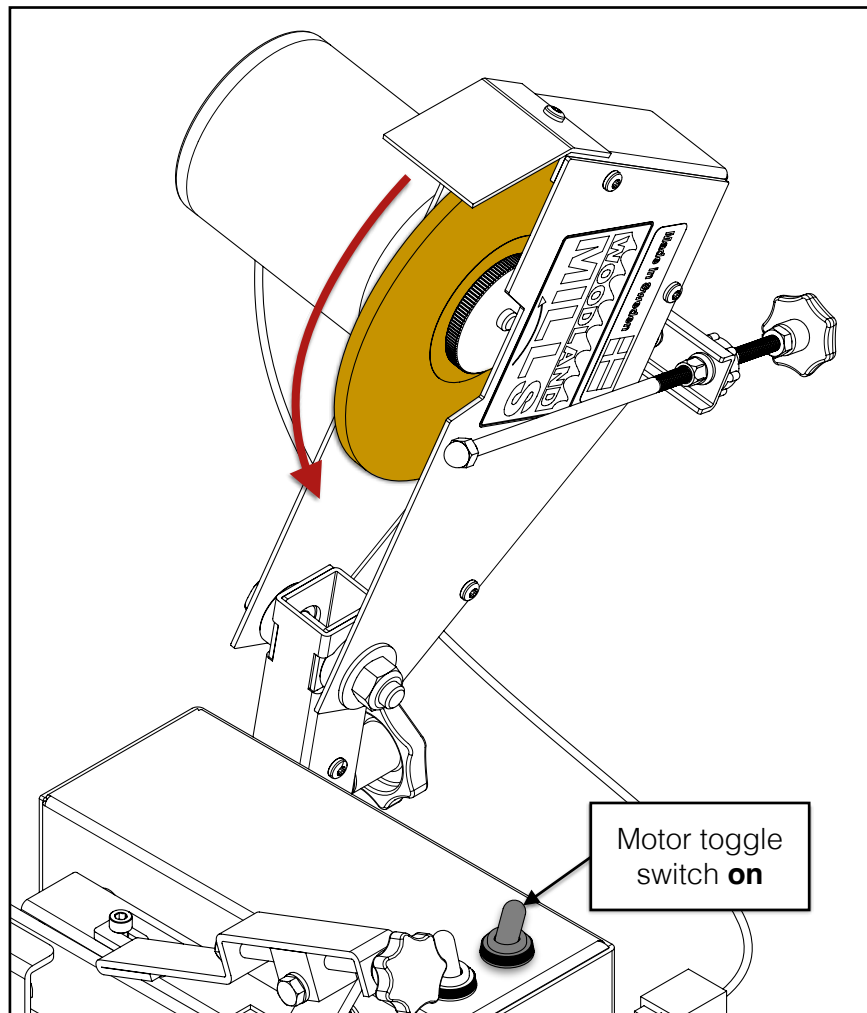

The sharpener ships with a new grinding disc with a square profile. This and any replacement discs will require profiling before sharpening a blade.

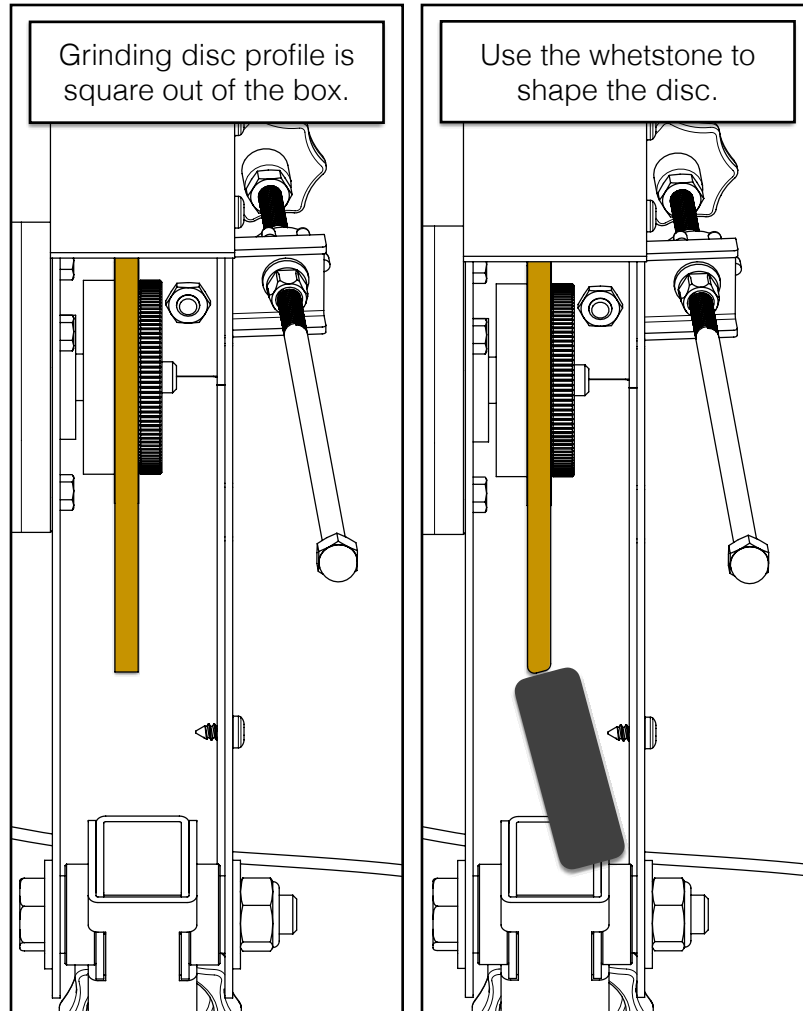

Remove a little material at a time with the whetstone while periodically checking the profile with the profiling template.

Turn the grinding wheel off before using the template.

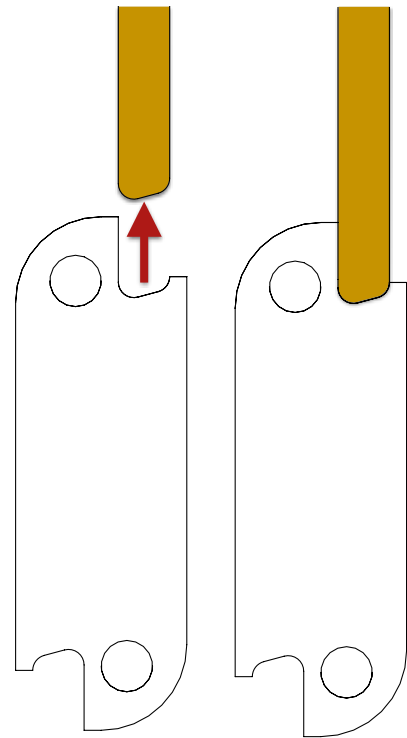

****The profiling template should only be used as a guide. Tooth profiles from different blade manufacturers can vary and, therefore, custom grinding disc profiles may need to be made.****

FUSES

The sharpener uses two (2) fuses of differing amperage: 0.5 A and 15 A. A spare for each is provided.

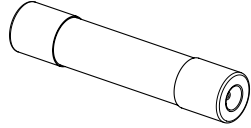
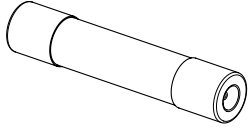
2x	0.5 A Fuse		2x	15 A Fuse	
----	------------	---	----	-----------	---

The 0.5 A fuse is located inside the connector that is inline with the wiring harness and the 15 A fuse is inside connector on the positive (red) battery clamp cable.

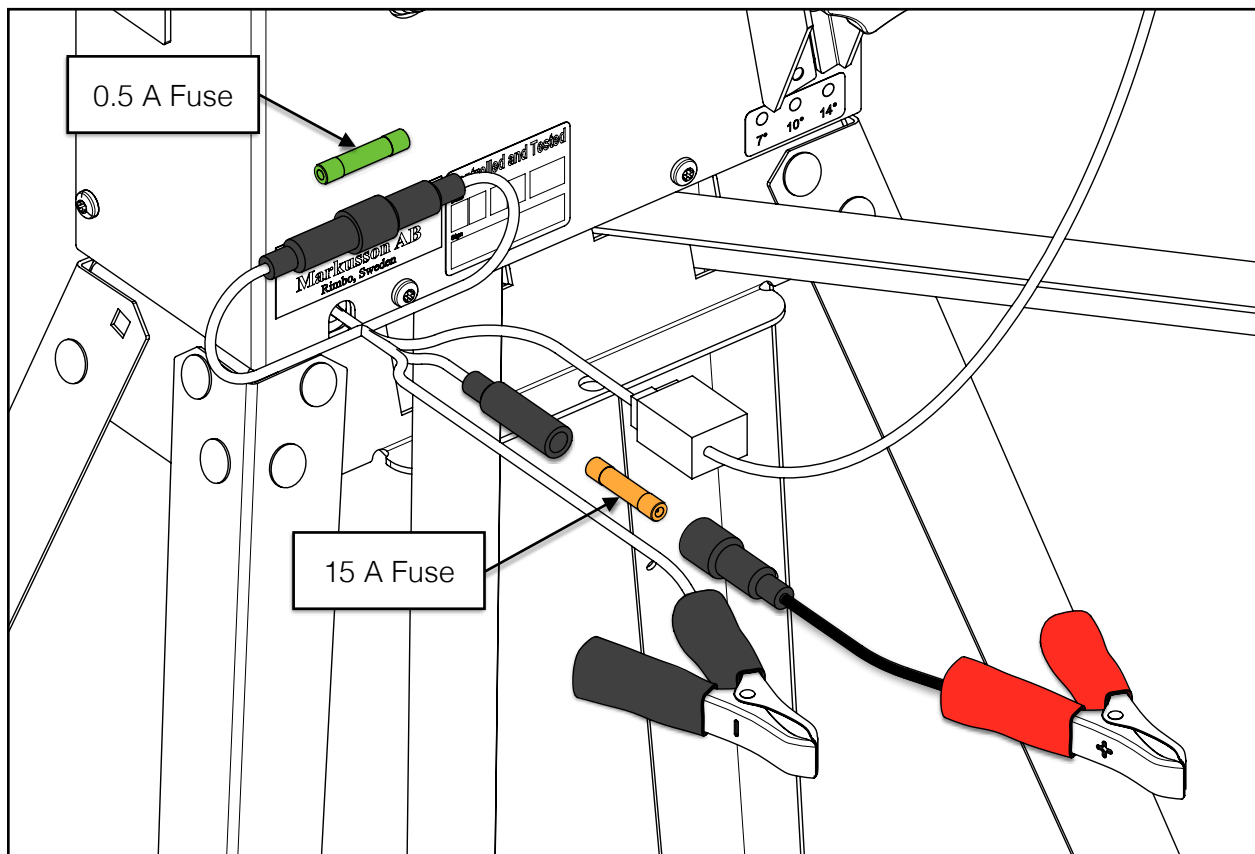

****Always be sure to connect the sharpener to an approved 12 V power source. Higher voltages could waste fuses and possibly damage the machine.****

OPERATION

1. SETTING THE HOOK ANGLE

Loosen the large knob on the back of the control box and rotate the grinding head to set the appropriate hook angle for the blade to be sharpened. Once set, tighten the locking knob.

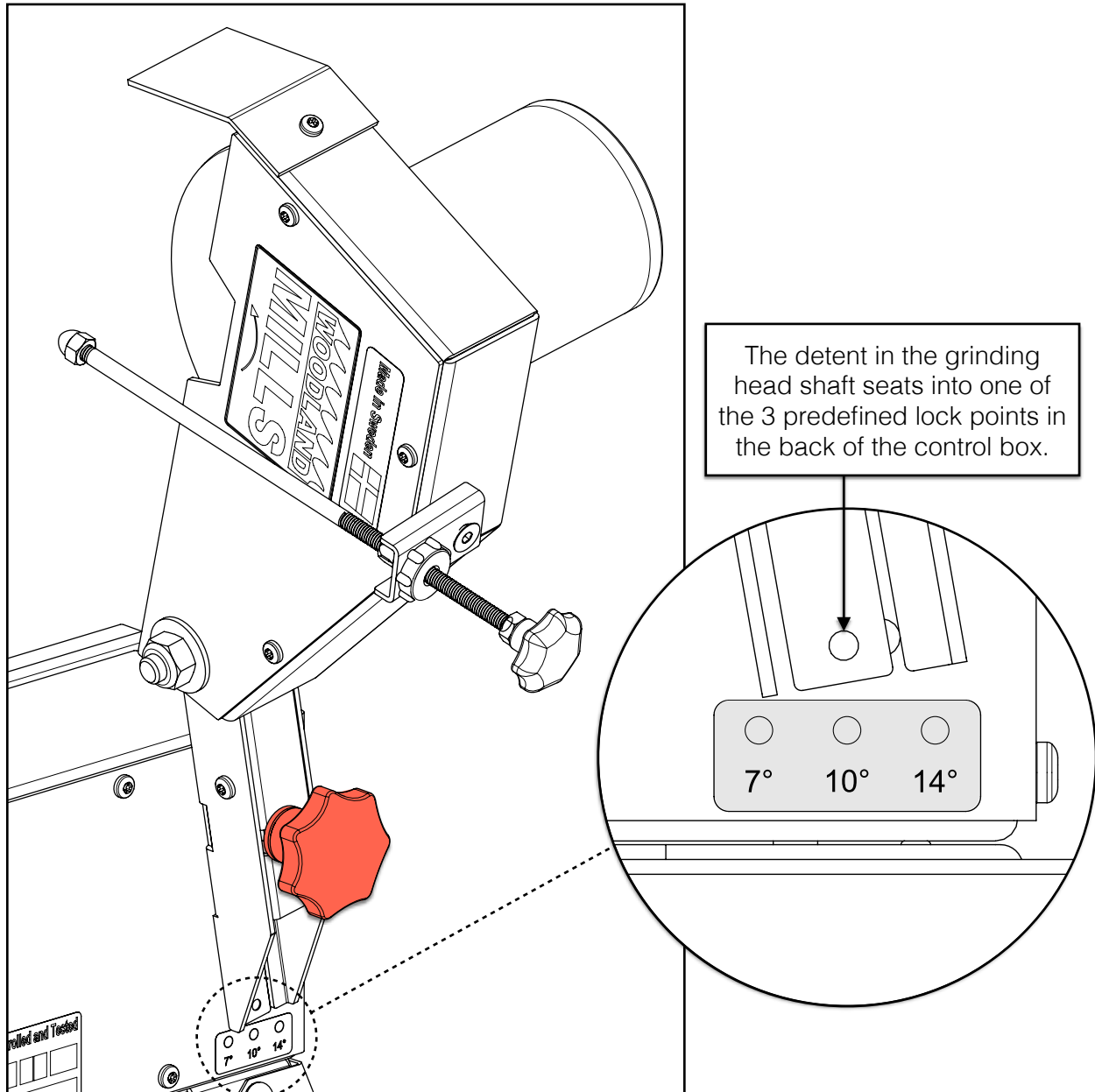

Note that the grinding head can be set to custom angles other than the three (3) predefined angles shown. Simply rotate the head as desired and lock it in place with the knob.



2. INSTALLING THE BLADE

A. BLADE SUPPORTS

First, seat the far side of the blade into the notches on each of the blade supports.

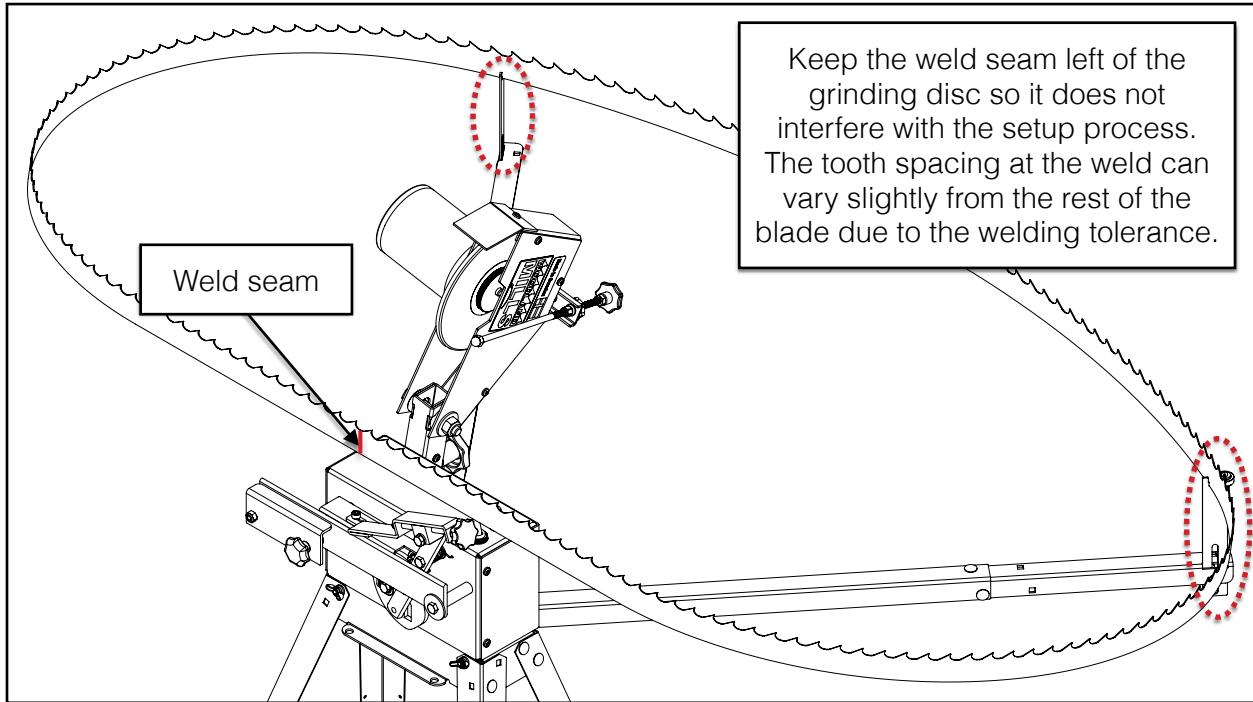

Note: adjust the position of both the outer support arms to suit the blade length if necessary. The blade should ride against the bearings at the end of the each blade support. See section, ***ADJUSTABLE OUTER SUPPORT ARMS***, for more information.

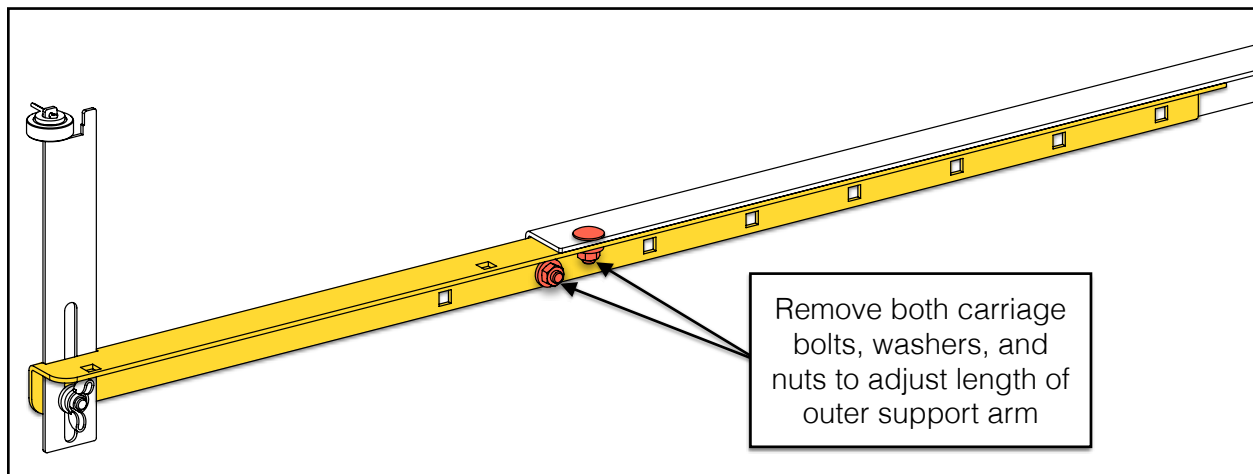

B. BACK REST

Position the near side of the blade so it slides down between the back rest and large washers.

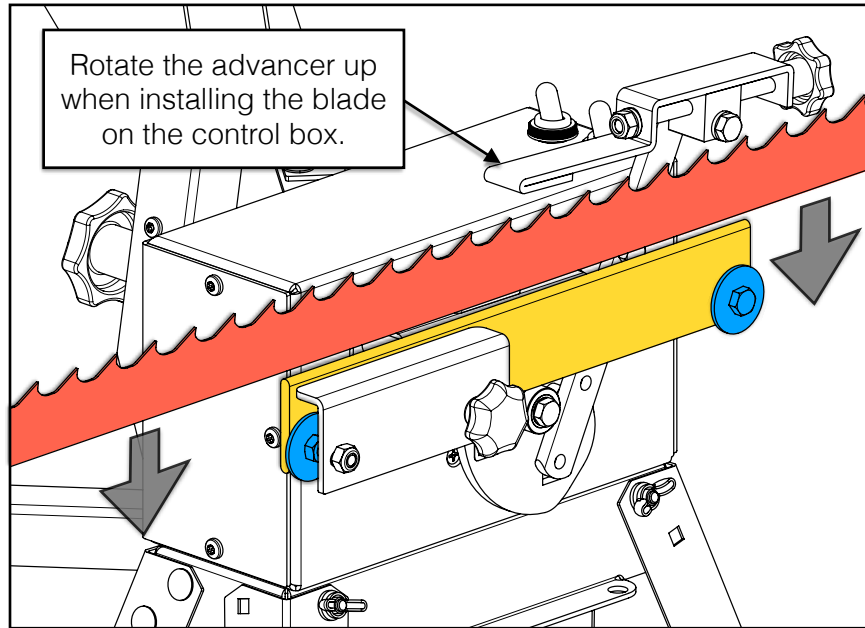

C. GUIDE PLATE

Tighten the knob on the guide plate until it bottoms out. The blade should slide left-but not move in or out (forwards or backwards).

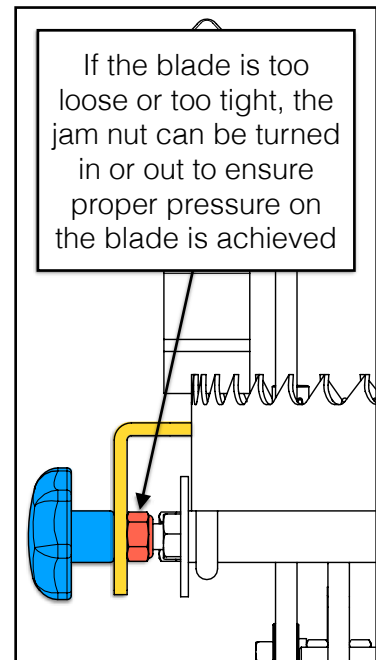
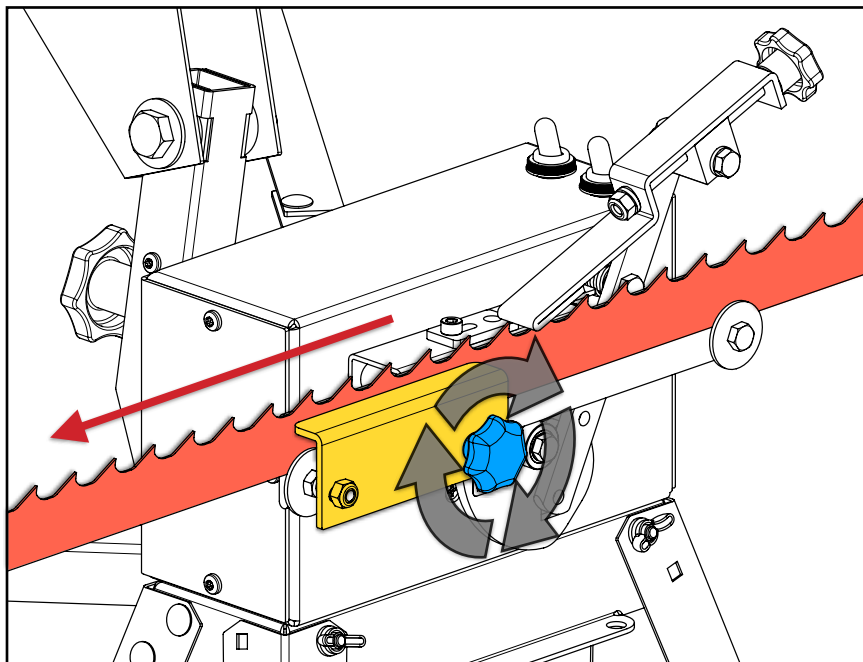

3. CALIBRATING THE ADVANCEMENT

A. CONNECT THE BATTERY

Before connecting the battery ensure both toggle switches are set to **STOP**.

Follow the battery polarity label on top of the control box: connect the **POSITIVE** clamp (+ red) to the positive battery terminal and the **NEGATIVE** clamp (– black) to the negative battery terminal.

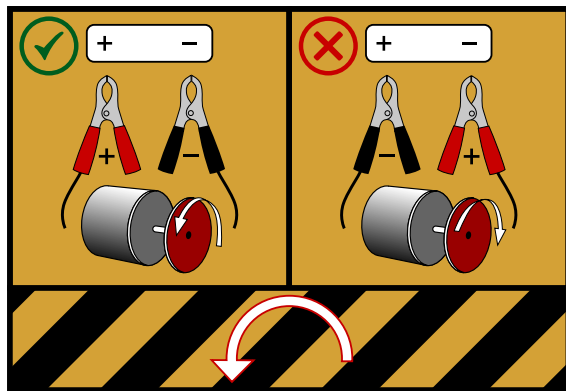

BATTERY POLARITY LABEL

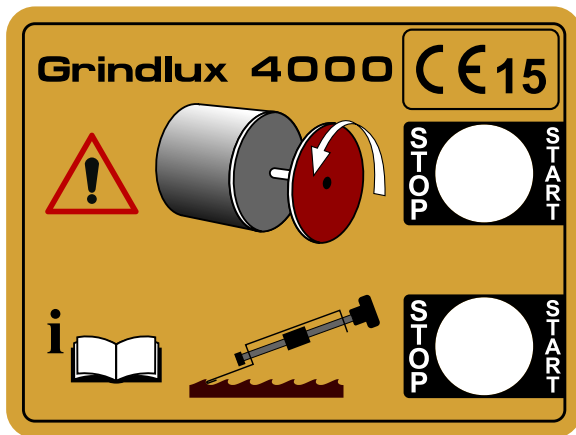

TOGGLE SWITCH LABEL

****Always remember to check that the toggle switches are in the STOP position before connecting the battery.****

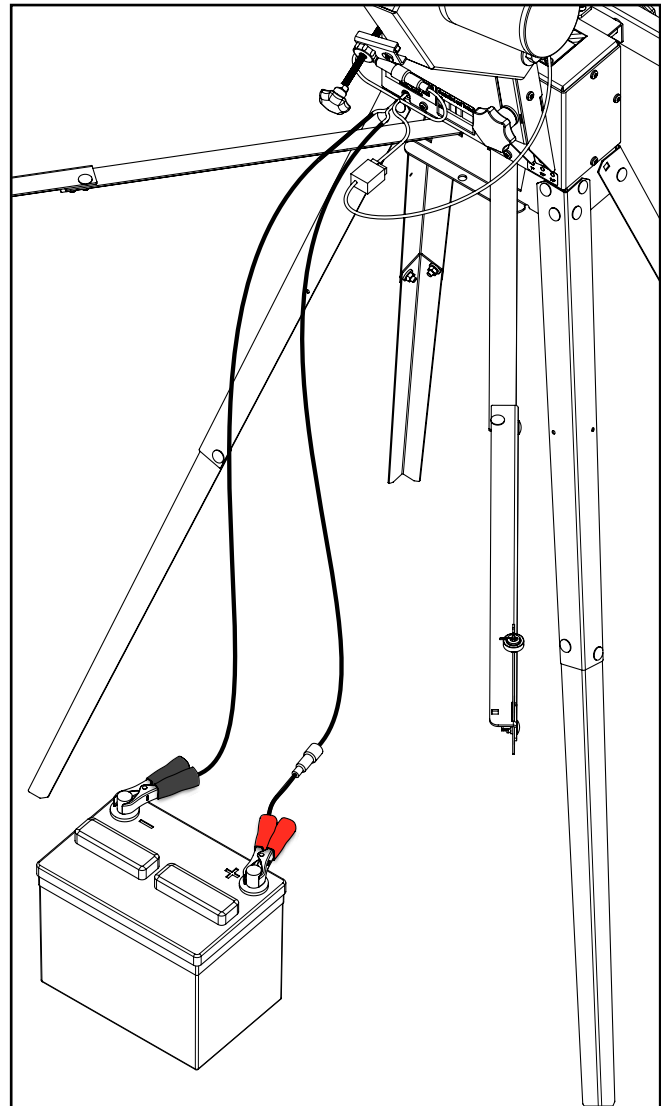

B. ADVANCE THE BLADE

Turn the advancer control on and allow the advancer to move the blade by two (2) teeth.

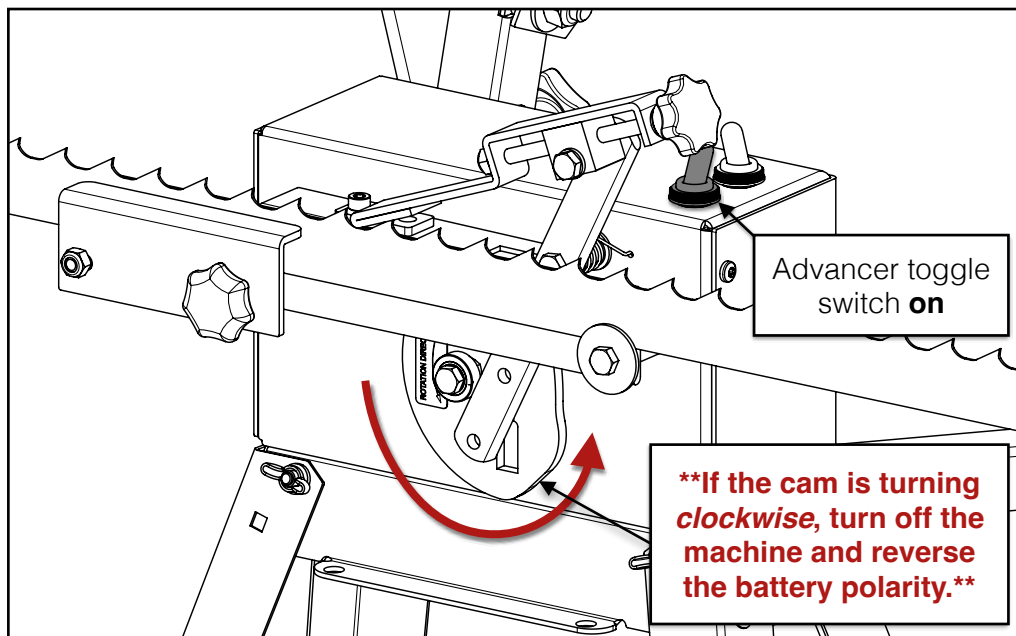

Turn off the toggle switch once the advancer has pushed the second tooth's hook face as far to the left as it will go and the lever is at its highest position.

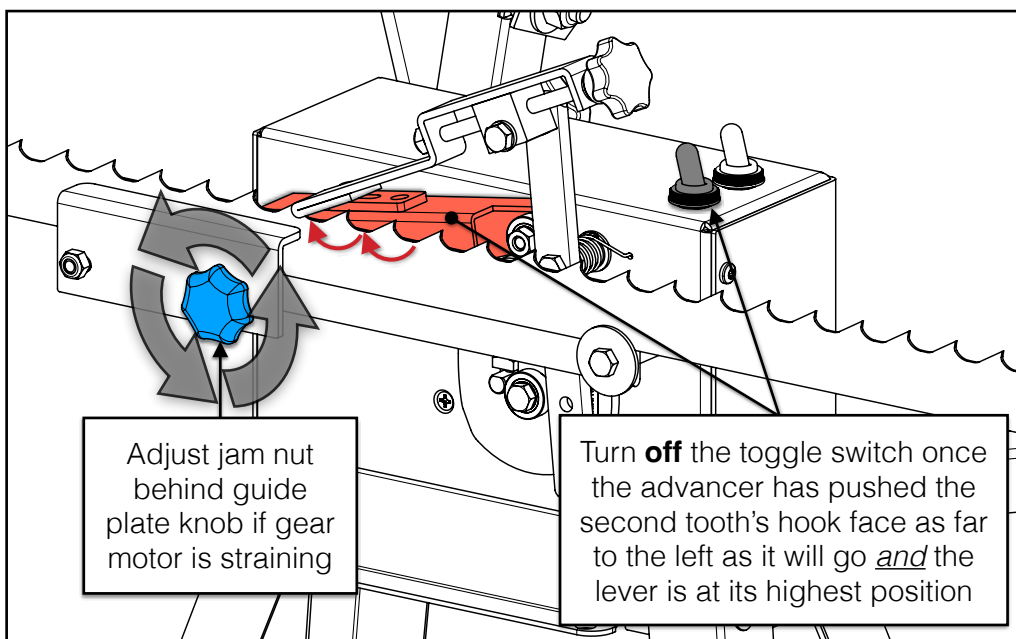

****Listen to the gear motor as the blade advances. If it gets loud and sounds like it is straining, the blade is too tight. Adjust the jam nut behind the guide plate knob.****

C. ROTATE THE GRINDING HEAD DOWN



Manually rotate the grinding head down—do not turn it on. Seat the acorn nut at the end of the depth adjustment rod into the hole in the stop plate.

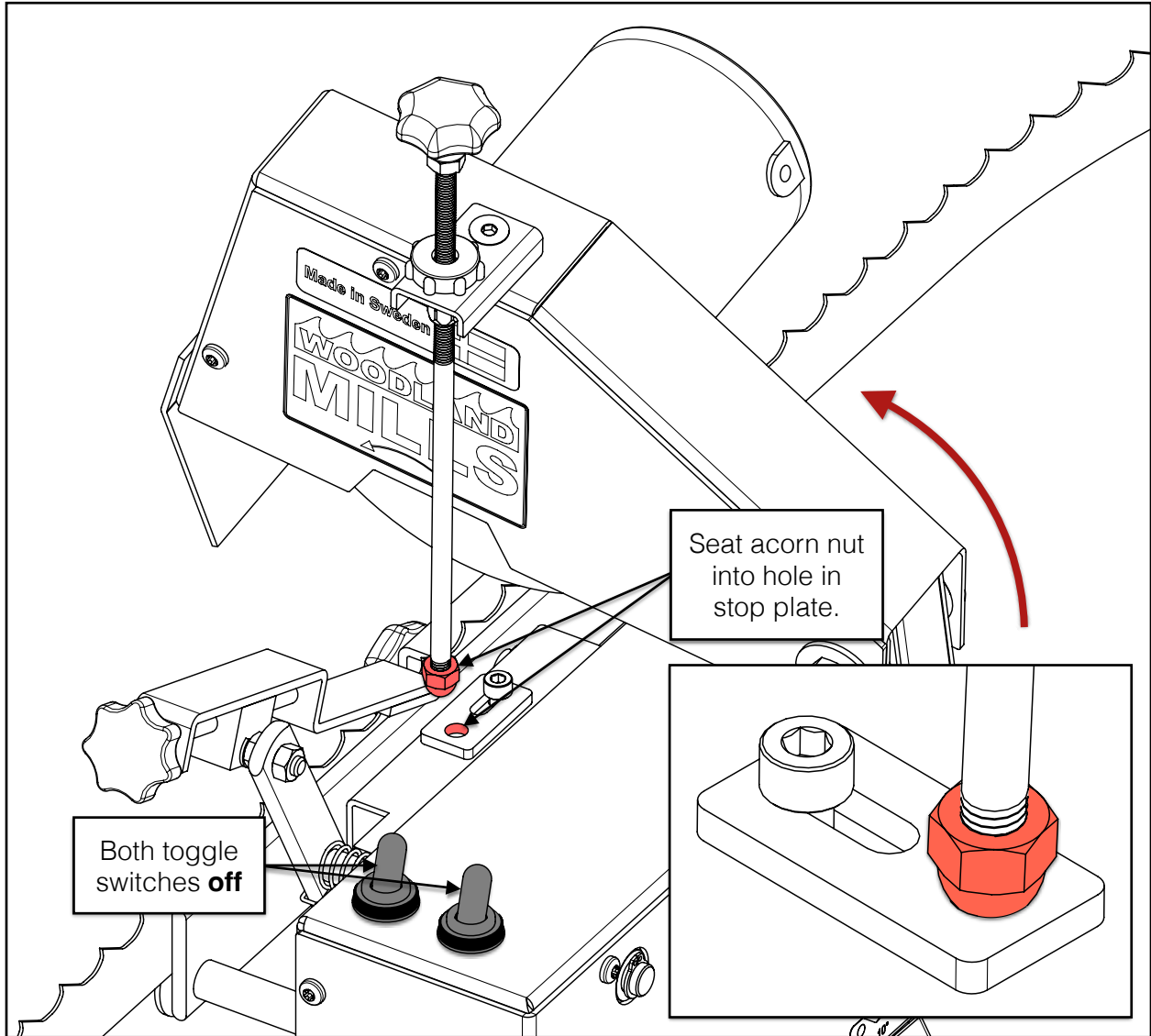



Turn the advancer on and observe the movement of the grinding disc relative to the tooth profile. Do not turn the grinding head on.

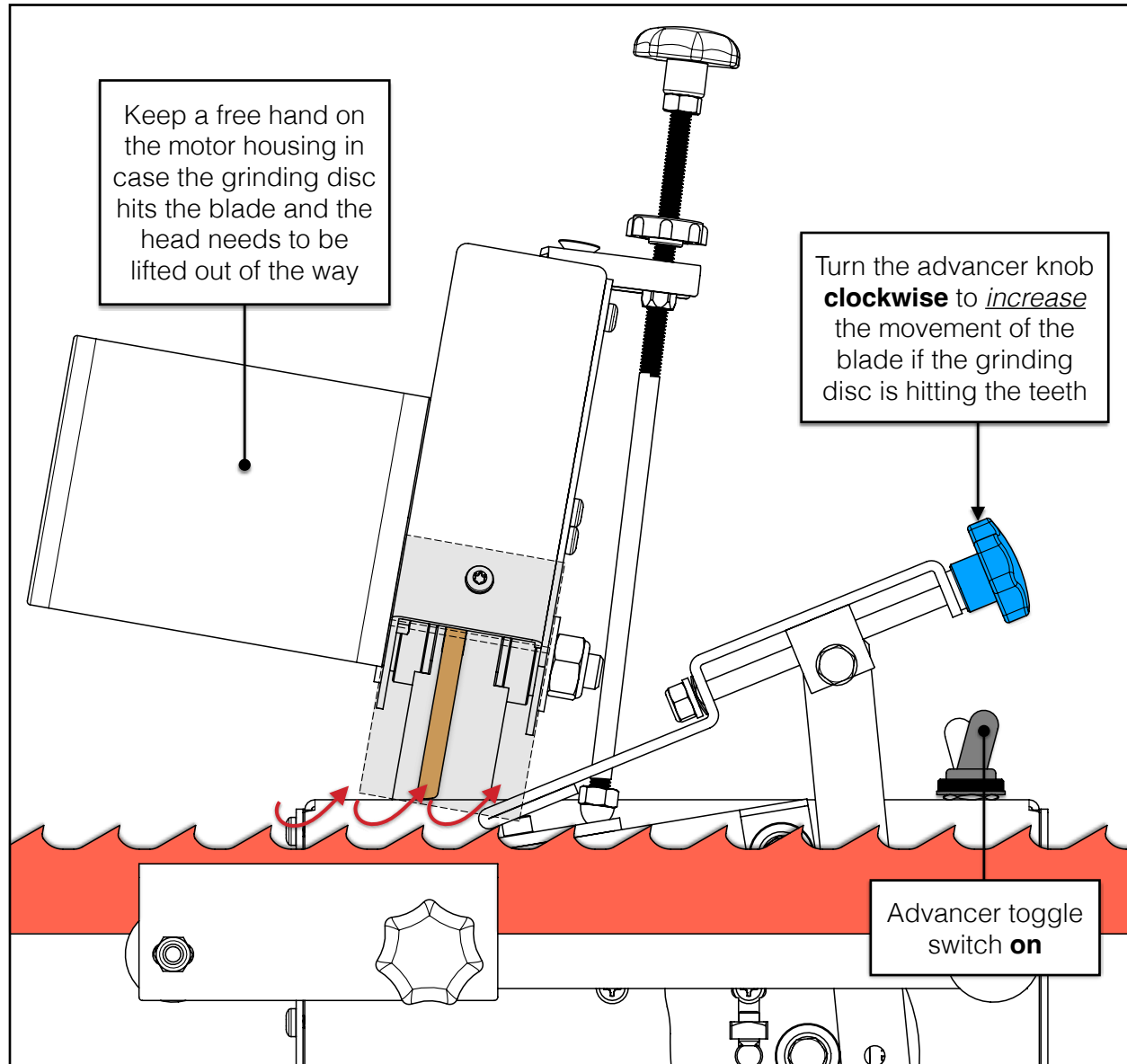

****Keep a free hand on the motor housing and be ready to lift the grinding head on the chance the grinding disc hits the blade.****

D. FINE-TUNE THE ADVANCEMENT

One half of the adjustment setting is fine-tuning the advancement so that the left face of the grinding disc is flush with the hook face of the tooth. 

Use the advancer knob to adjust how far the blade is pushed to the left. Turning it *clockwise* will push the blade farther to the left while *counter-clockwise* will back off the advancer and reduce the blade's leftward movement.

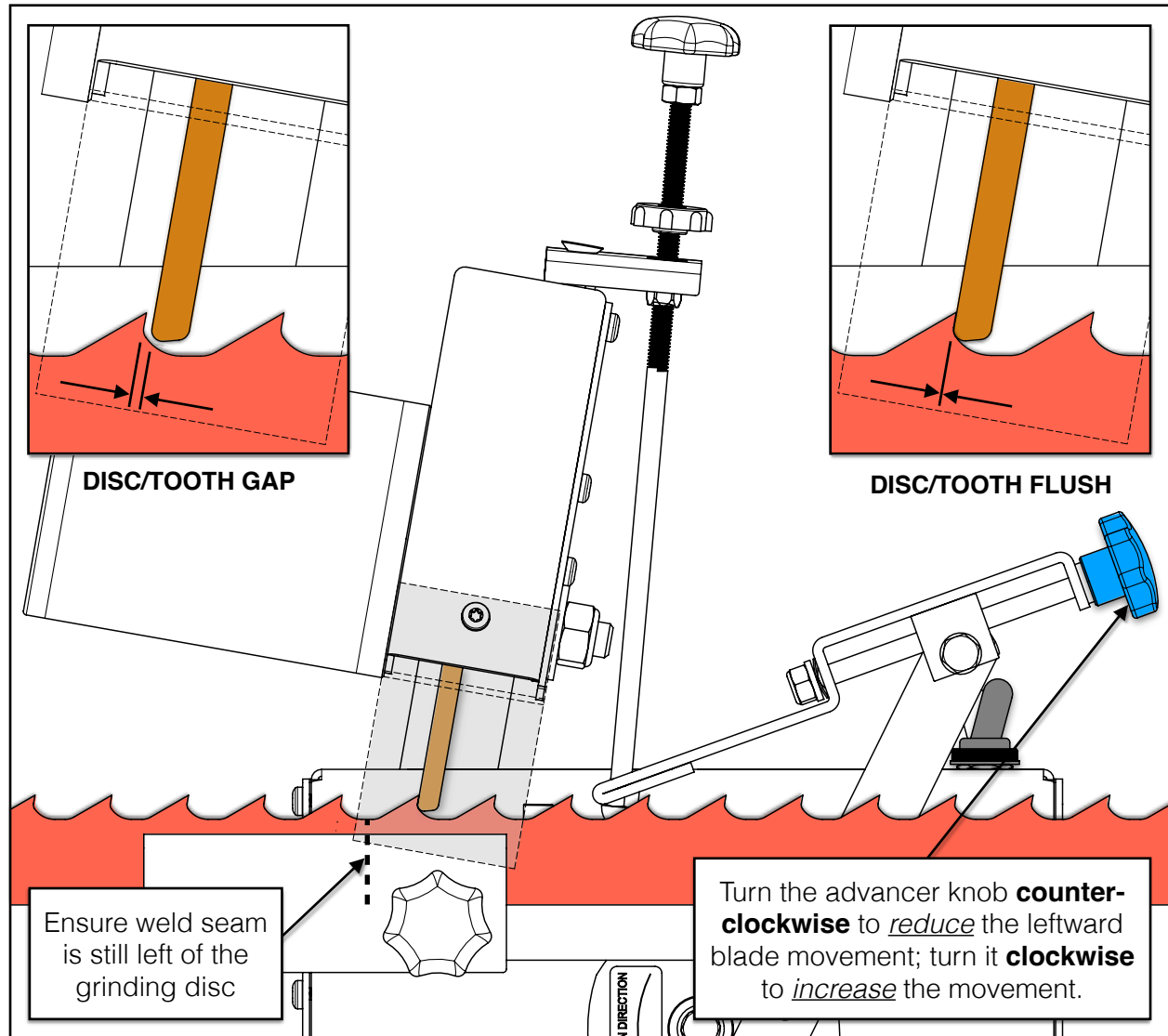

****Setting up a blade for sharpening requires a combination of both the advancement adjustment and the grinding head movement steps. Read and understand both sections before starting to fine-tune the sharpener.****

E. FINE-TUNE THE GRINDING HEAD MOVEMENT

The other half of the adjustment setting is fine-tuning the grinding head height so that the bottom of the grinding disc touches the bottom of the tooth gullet.

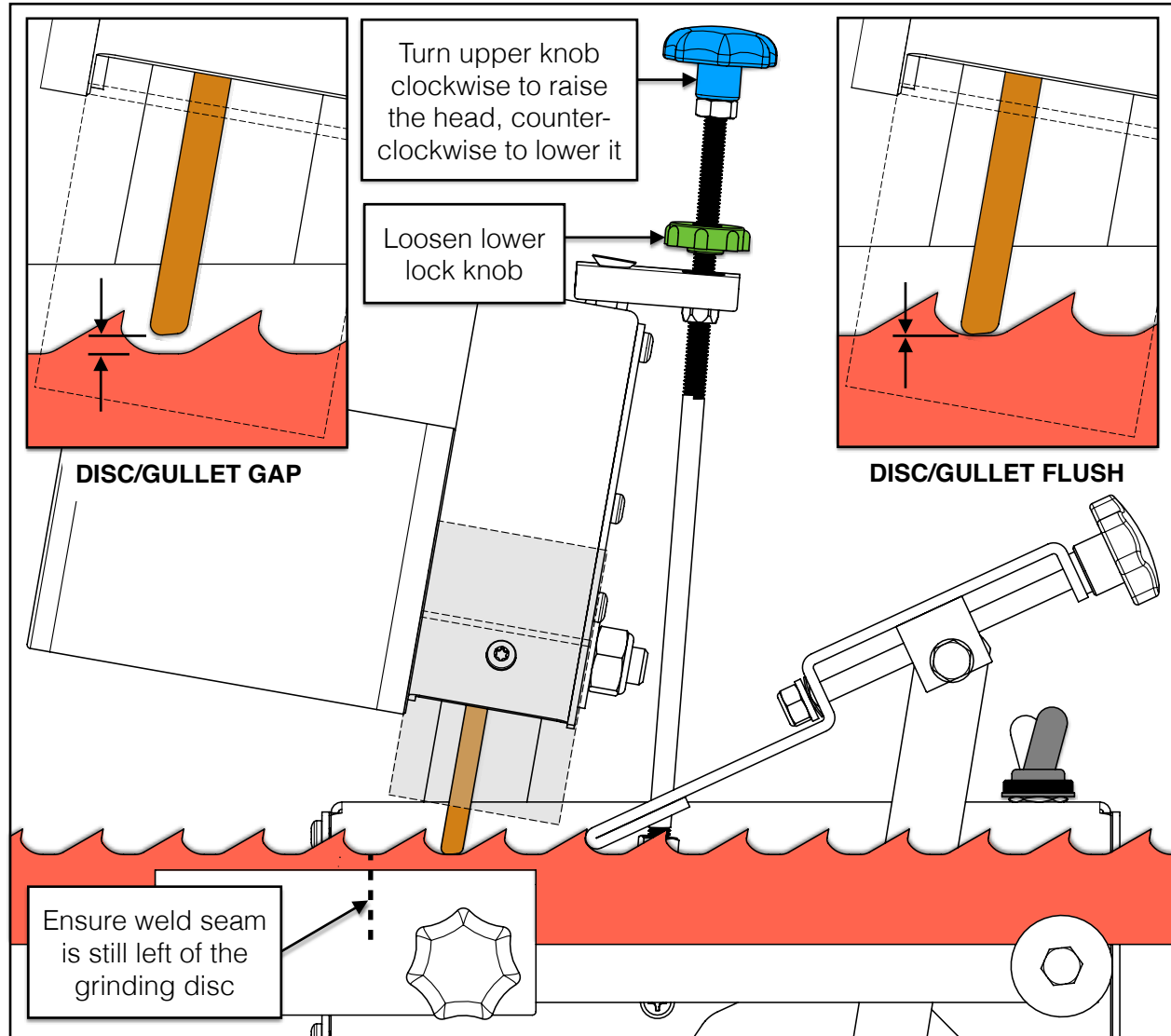

Loosen the lower lock knob counter-clockwise so the depth adjustment rod can move freely. This knob simply acts as a locking mechanism for the rod once the proper depth has been set.

Turn the upper knob to adjust the depth of the grinding head. Clockwise raises the head; counter-clockwise lowers it. Tighten the lock knob once the depth has been set.

****Setting up a blade for sharpening requires a combination of both the advancement adjustment and the grinding head movement steps. Read and understand both sections before starting to fine-tune the sharpener.****

As the disc leaves the gullet it should completely clear the next tooth's back angle profile.

If the blade tooth profile has a steep back angle, adjust the position of the stop plate by flipping up the lever and loosening the M5 socket head cap screw and lock nut. This adjustment will allow the grinding disc to clear the tooth as it exits the gullet.

Retighten the cap screw and lock nut after moving the stop plate.

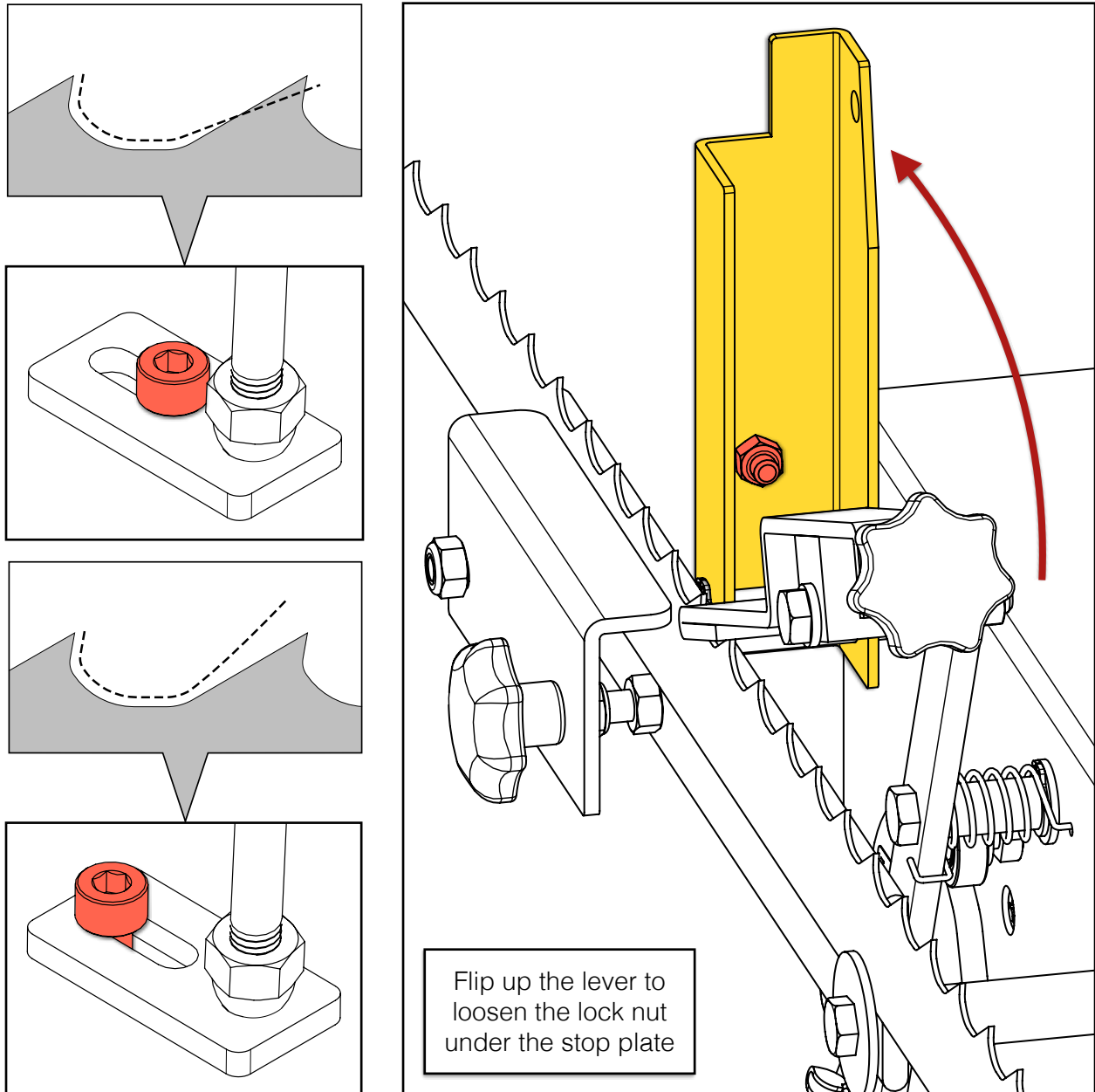

4. SHARPENING



With the machine now setup for the blade to be sharpened, follow the steps below to begin sharpening the teeth.

A. ADVANCE THE BLADE

Lift the grind head and while holding the advancer up, manually pull the blade back through until the weld seam is *right* of the grinding disc. Turn on the advancer toggle switch, advance the blade through until the weld seam is just *left* of the grinding disc, and then turn the switch off.

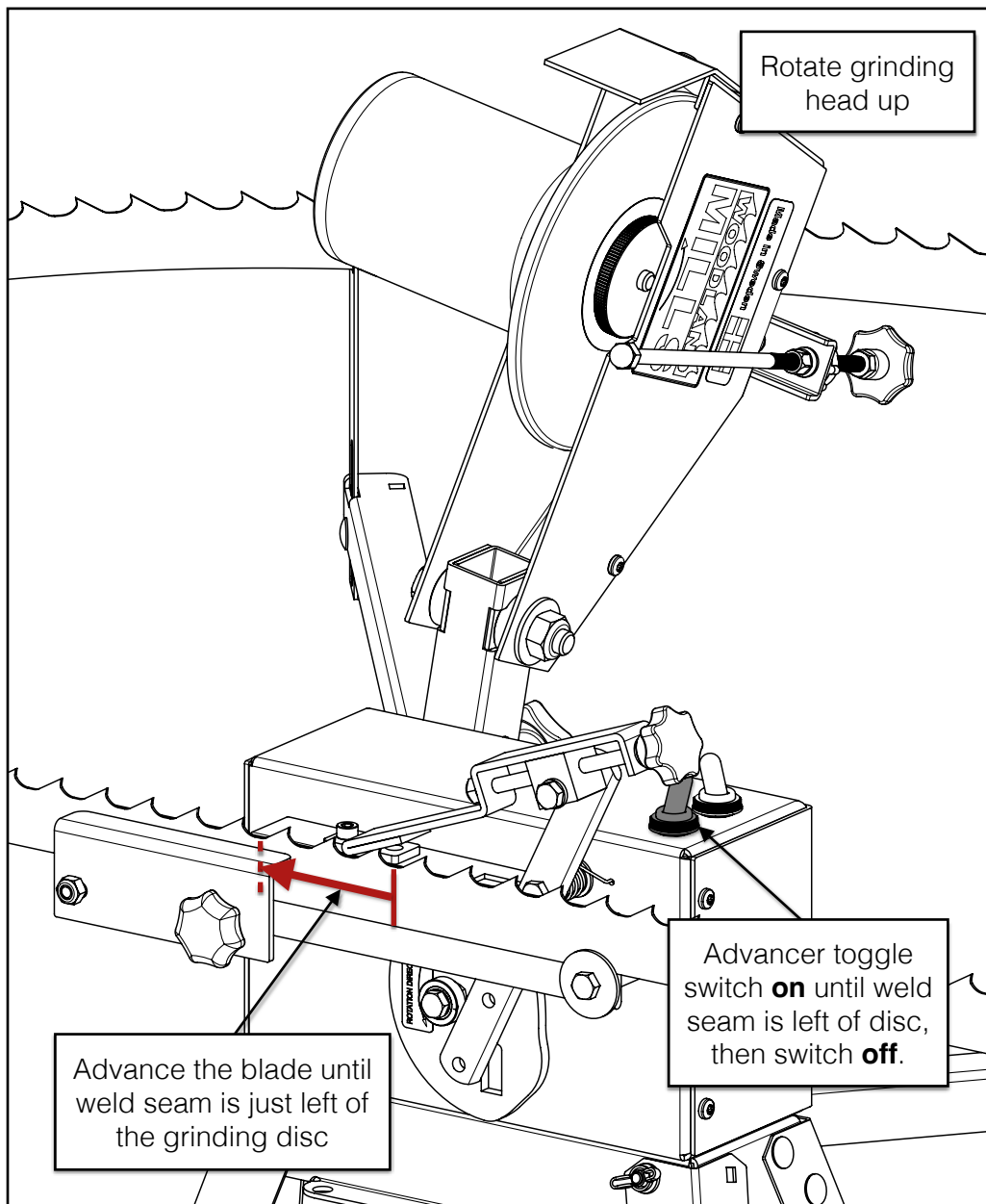

B. SET GRIND DEPTH



Rotate the grinding head down and seat the acorn nut in the stop plate hole. Turn on both the *advancer* *and* grinder toggle switches.

Make small adjustments to the advancer and depth adjustment rod to achieve a light grinding sound where approximately 0.004-0.008 in [0.1-0.2 mm] is being removed.

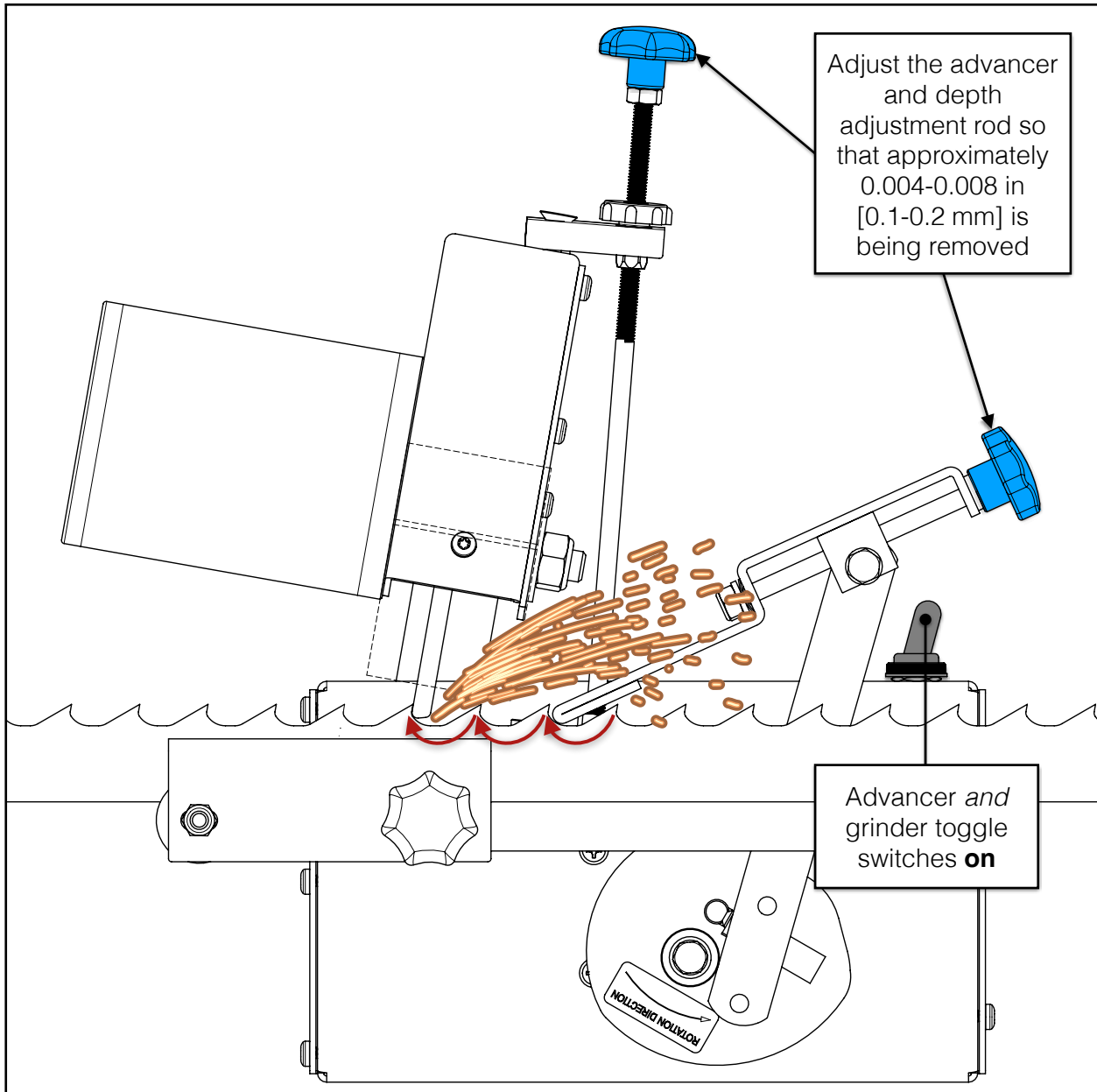

C. POSITION THE AUTO-STOP

Attach the auto-stop to the blade to automatically stop the sharpener once all the teeth have been ground.

1x	Auto-Stop	
----	-----------	---

It is important to correctly position the auto-stop in order to stop the sharpener before the blade weld seam reaches the grinding head. See "**Auto-Stop Activated**" graphic on next page.

Once the sharpener has ground 6-10 teeth (the number of teeth is dependant on the blade pitch), set the auto-stop on the closest blade tooth approximately 7 in [178 mm] right of the weld seam (e.g. 8 teeth from the weld on $\frac{7}{8}$ in [22 mm] pitch blades).

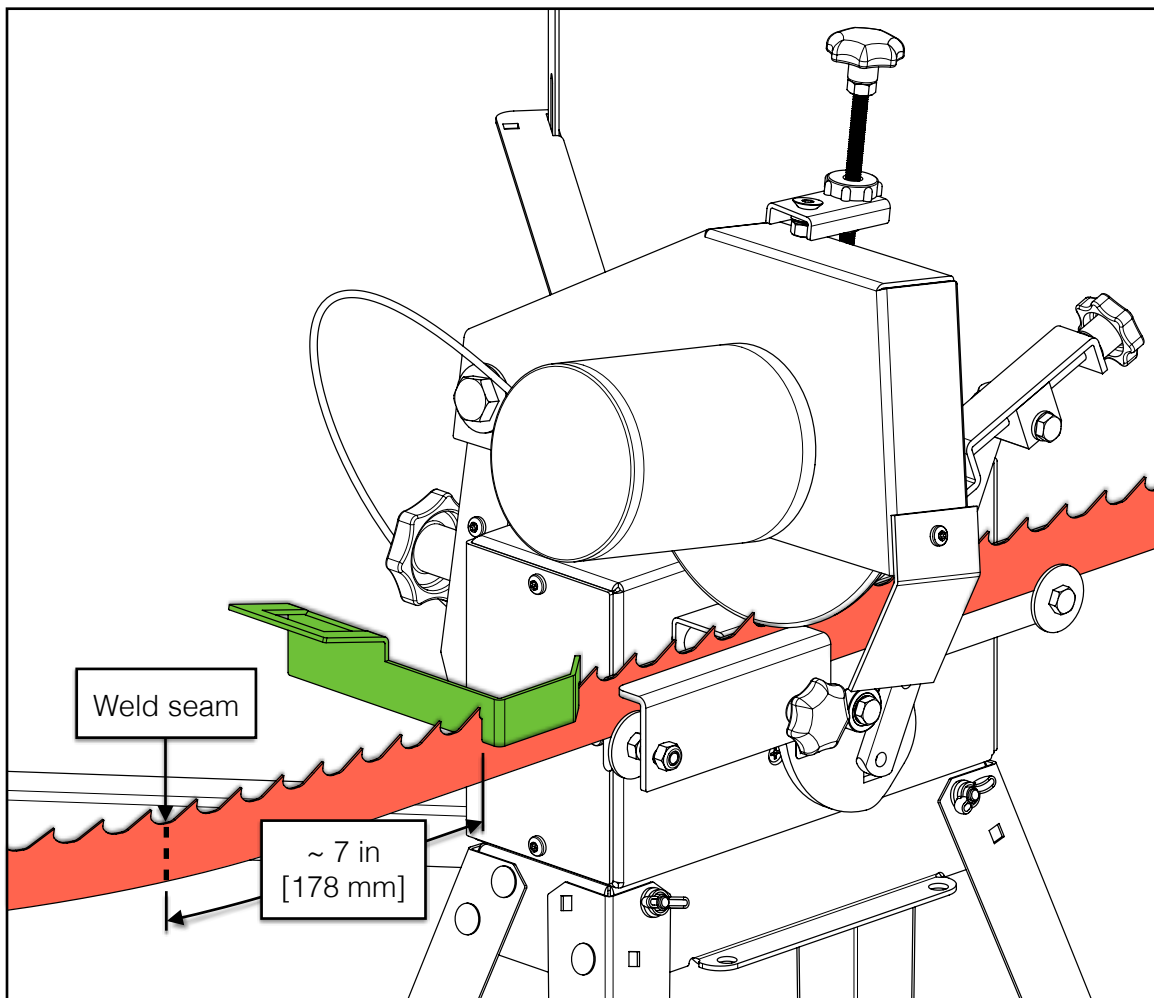

When the auto-stop is positioned correctly it triggers the toggle switches just before the blade weld seam reaches the grinding disc.

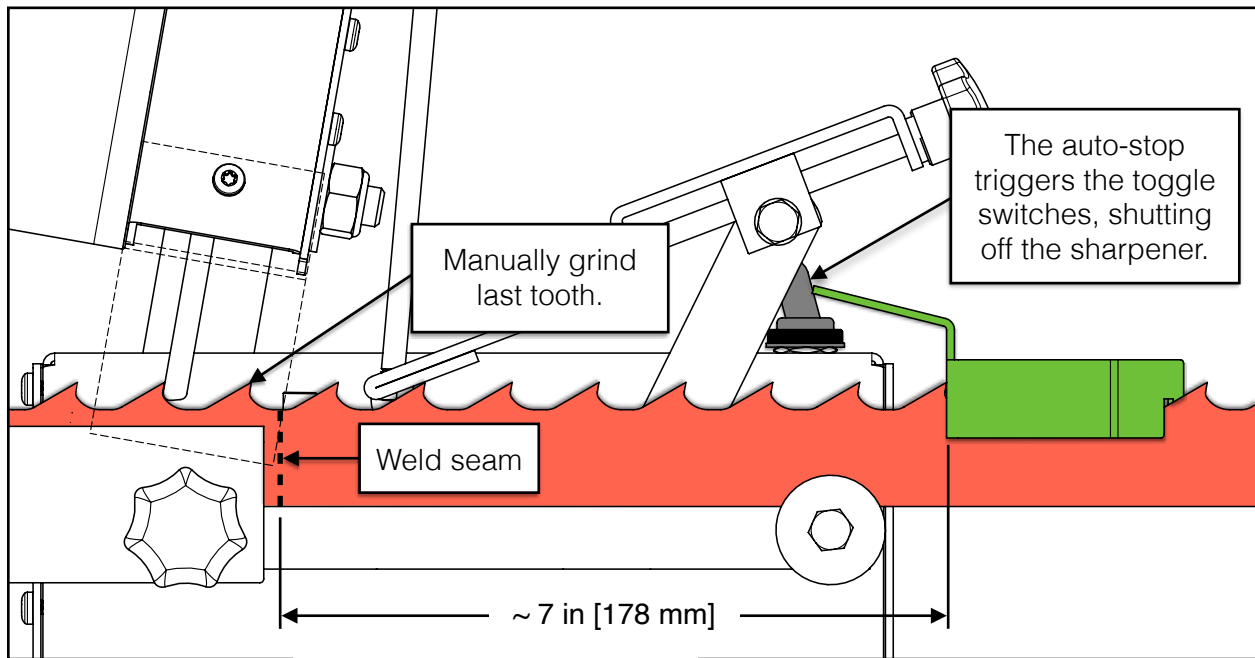

AUTO-STOP ACTIVATED

The last tooth can be ground manually by moving the blade and lowering the grinding head by hand to sharpen the hook face.

STORAGE

The sharpener footprint can be reduced significantly by folding the front legs back. It can then be stored up against a wall or, hung from it, or fit in the back of a vehicle for easier transport.

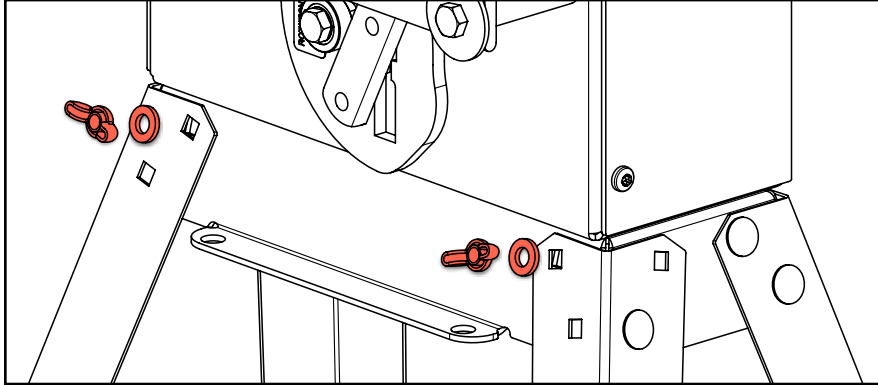

Remove both support arms first. Then remove the wing nut, washer, and carriage bolt from the front of each leg. Push each leg backward and the mounting base will flex to accommodate the movement.

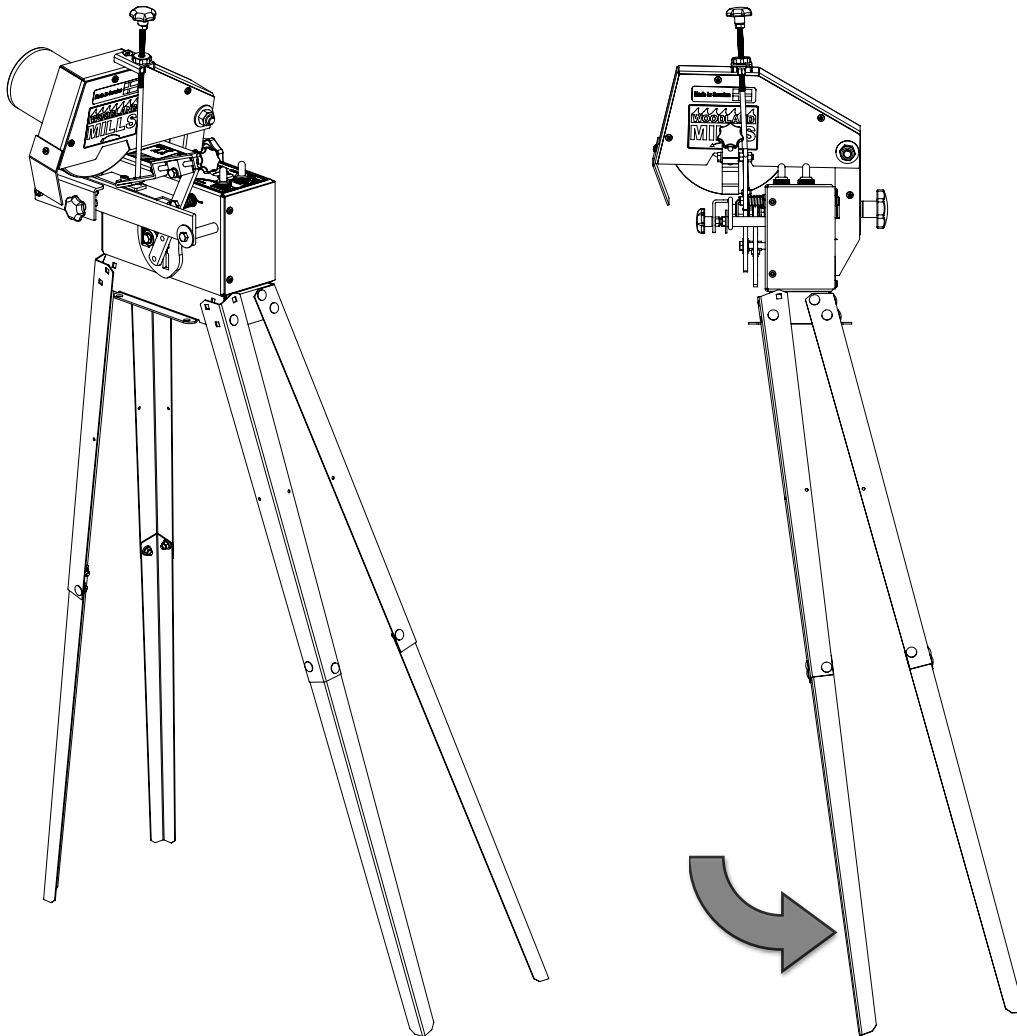

REPLACEMENT PARTS ORDERING

When ordering replacement parts, first locate the balloon number(s) from the appropriate ***exploded assembly view*** as shown in the example below:

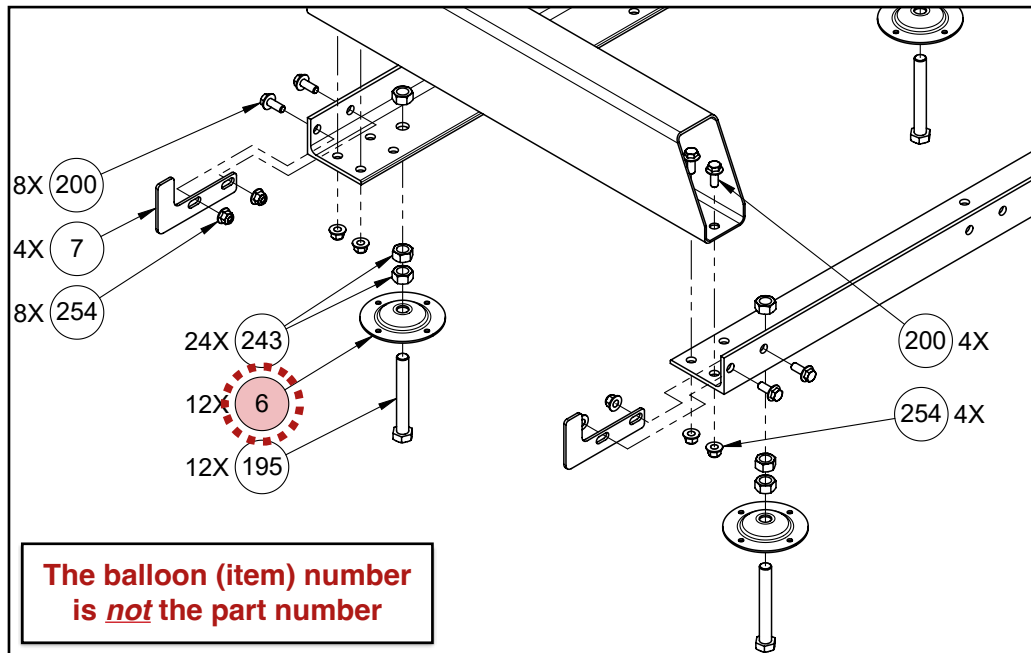

Next, turn to the ***Parts List*** section and locate the balloon number in the “**Item**” column:

PARTS LIST				
Item	Quantity		Part No.	Description
	14 hp	9.5 hp		
1	4	4	0001073	TRACK RAIL, 58.5 mm TALL
2	2	2	0001075	LOG BUNK, END
3	2	2	0001080	LOG BUNK, MID
4	1	1	0001084	LOG BUNK, CENTER
5	2	2	0001072	REINFORCEMENT PLATE, 90 X 200 mm
6	12	12	0001071	LEVELLING FOOT BASE
7	4	4	0001055	CARRIAGE STOP
8	1	1	0001062	LOG CLAMP SHAFT AND BRACKET WELDMENT

Record the part number (e.g. *0001071*, *HHB-MBM080FCJ*, etc.) in the “**Part No.**” column.

Contact Woodland Mills through the website or via phone/email. If possible, include the invoice or sales number from the purchased product so an associated account can be located. If the account has multiple addresses on file, please indicate to which address the replacement part(s) will be shipped.

TROUBLESHOOTING

Problem/Issue	Possible Causes	Resolution Options
No power	<ol style="list-style-type: none"> 1. Battery cables not connected. 2. Battery cable polarity reversed. 	<ol style="list-style-type: none"> 1. Connect the sharpener to a 12 Volt battery. Refer to page 26. 2. Ensure the polarity is correct or the sharpener will not power on. Refer to page 26.
Advancer not rotating	<ol style="list-style-type: none"> 1. Nut between advancer and connecting arm is too tight against the advancer instead of being tight against the connecting arm. 	<ol style="list-style-type: none"> 1. Ensure the advancer is assembled to the connecting arm properly where the two (2) jam nuts are tight around the connecting arm and not tight to the advancer. Refer to page 17.
Blade not advancing smoothly	<ol style="list-style-type: none"> 1. Advancer is over-tight. 2. Pressure plate is too tight against blade. 	<ol style="list-style-type: none"> 1. Ensure the advancer is assembled to the connecting arm properly where the two (2) jam nuts are tight around the connecting arm and not tight to the advancer. Refer to page 17. 2. Jam nut behind pressure plate knob may require adjustment. Refer to page 35 and page 37.
Gearmotor straining	<ol style="list-style-type: none"> 1. Pressure plate is too tight against blade. 2. Blade getting hung up on support arm brackets. 	<ol style="list-style-type: none"> 1. Jam nut behind pressure plate knob requires adjustment. Refer to page 35 and page 37. 2. The blade is pushing out or pulling in against the support arm bracket bearings. Adjust the support arm lengths to suit the length of blade. Refer to pages 23 and 24.
Grinding head not moving smoothly up and down during sharpening	<ol style="list-style-type: none"> 1. Depth adjustment rod bracket screw on top of grinding head too tight. 	<ol style="list-style-type: none"> 1. Loosen the screw on top of the grinding head enough to allow controlled movement of the bracket but not so loose that it is affected by gravity. Take care to ensure the two (2) jam nuts securing the bracket to the grinding head housing are tight.

EXPLODED ASSEMBLY VIEWS

STAND

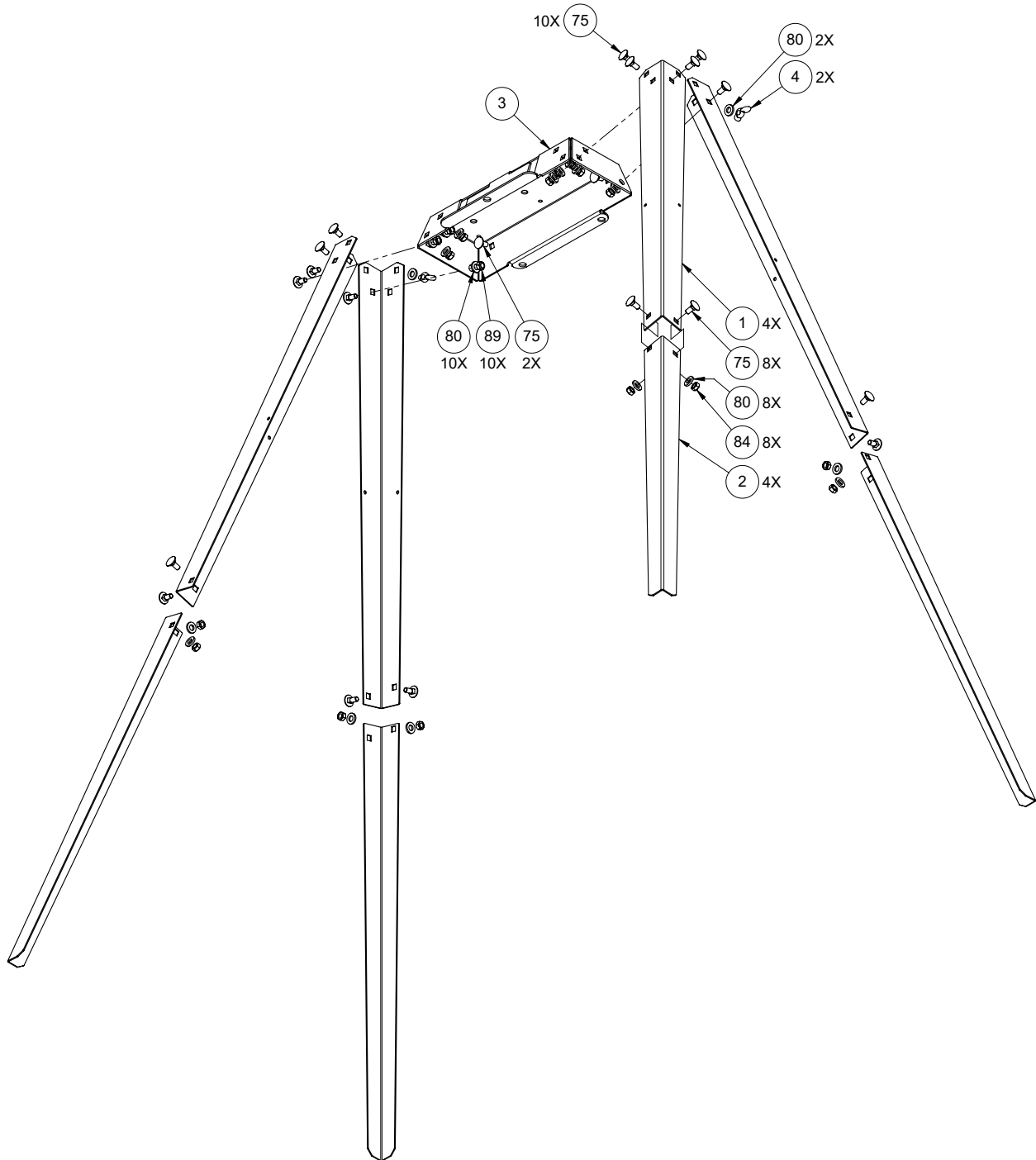

CONTROL BOX

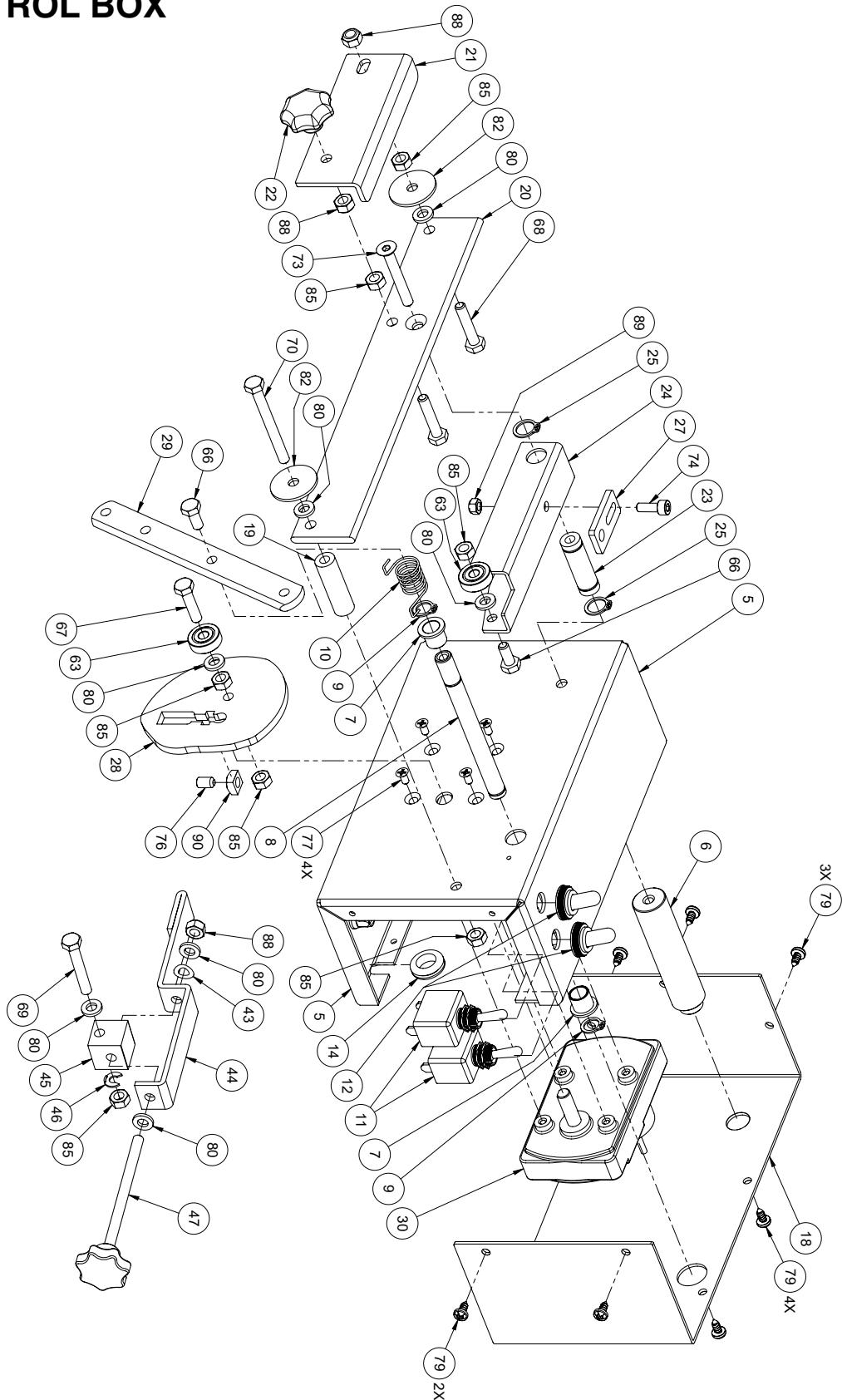

CONTROL HEAD TO STAND

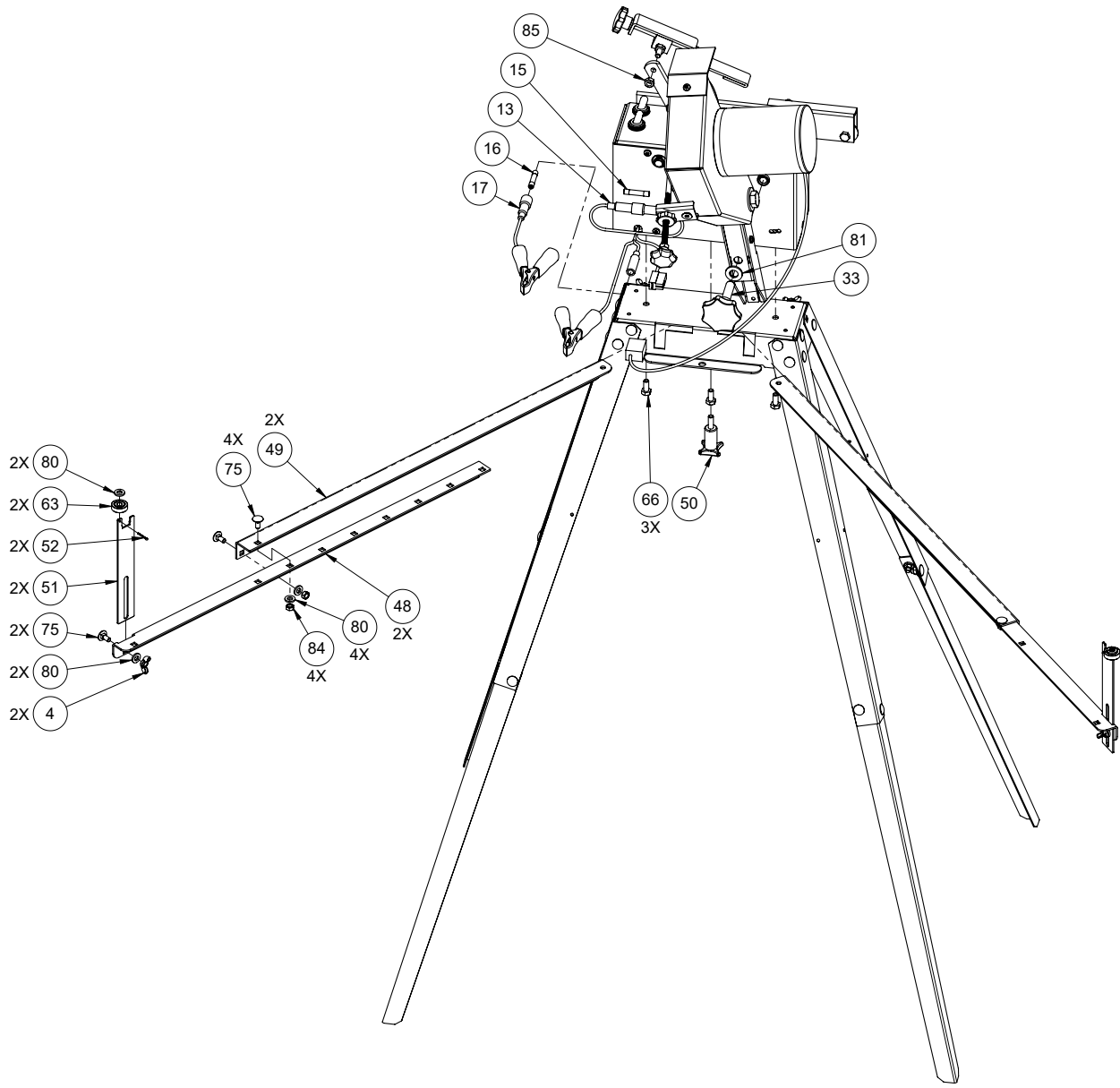

ACCESSORIES AND LABELS

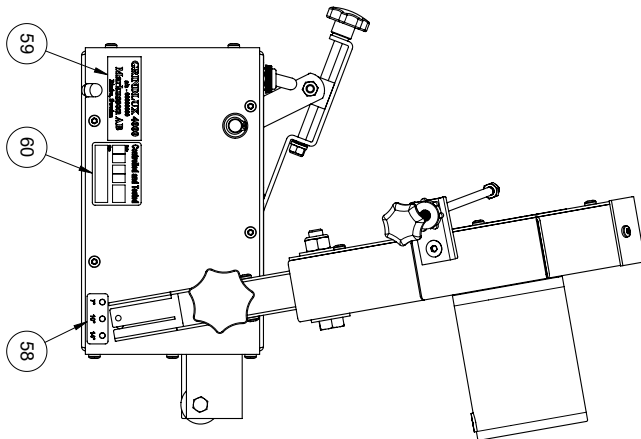
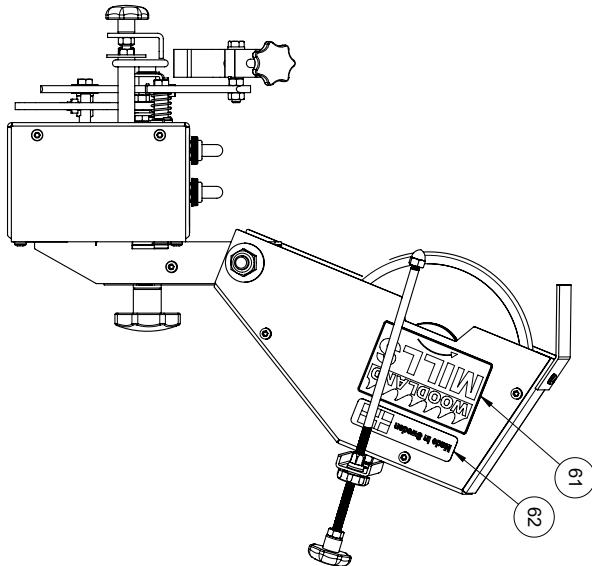
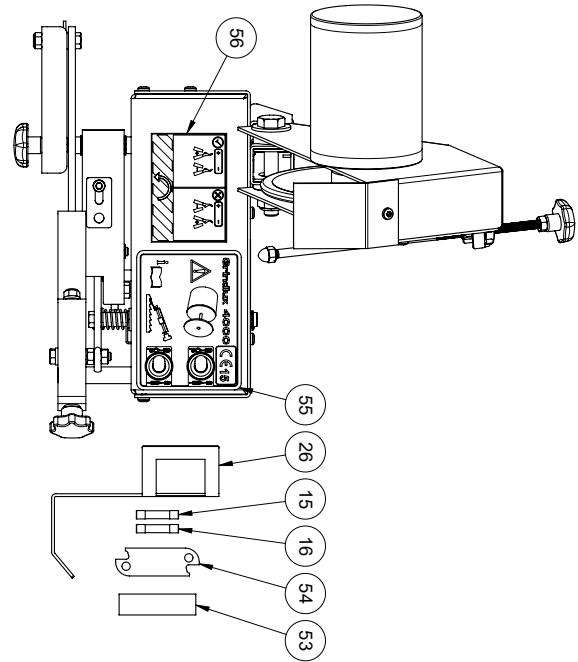
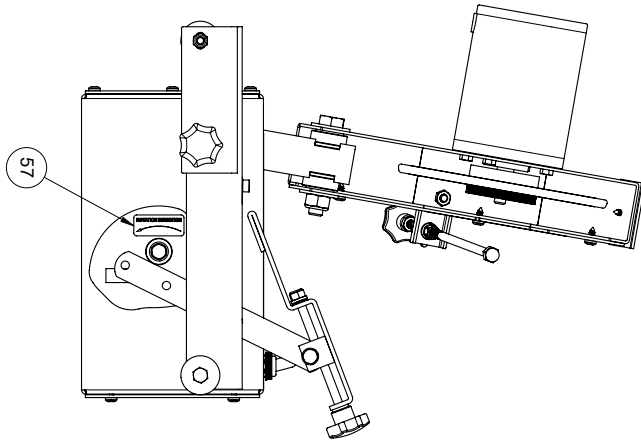

PARTS LIST

Item	Qty	Part No.	Description
1	4	0001557	UPPER LEG
2	4	0001558	LOWER LEG
3	1	0001554	MOUNTING BASE
4	4	0006216	WING NUT, TYPE D / STYLE 1, SST, M5 X 0.8
5	1	0003815	CONTROL BOX FRONT COVER
6	1	0003816	MOUNTING ARM SHAFT
7	2	0003817	BRONZE BUSHING, 12 mm OD, 10 mm BORE
8	1	0003818	CONNECTING ARM SHAFT
9	2	0004794	RETAINING RING, EXTERNAL, 10 mm SHAFT (9.6 mm GROOVE)
10	1	0003985	TORSION SPRING, HOOK ENDS, 0.575 in OD, 0.045 in DIA WIRE, 5 COILS
11	2	0003820	TOGGLE SWITCH, 15 A 250 VAC / 20 A 125 VAC
12	2	0003806	TOGGLE SWITCH CAP, M12 THD
13	1	0003682	WIRE HARNESS
14	1	0004885	PUSH-IN GROMMET, 12 mm ID, 20 mm OD, 6 mm WIDE, 9.5 mm HOLE, 2 mm MAT'L
15	2	0003807	FUSE, F0.5AL250V
16	2	0003808	FUSE, F15AL250V
17	1	0004104	BATTERY CLAMP, POSITIVE, 30 A
18	1	0003814	CONTROL BOX REAR COVER
19	1	0001582	SPACER, 12 OD, 6 ID, 40mm LG
20	1	0001581	BLADE BACK REST
21	1	0001580	GUIDE PLATE
22	2	0003981	KNOB, MULTI-LOBE, 32 mm OD, M6 X 1, 12 mm DP
23	1	0001585	LEVER SHAFT
24	1	0001584	LEVER
25	2	0004795	RETAINING RING, EXTERNAL, 12 mm SHAFT (11.5 mm GROOVE)
26	1	0001560	AUTO STOP
27	1	0001587	STOP PLATE
28	1	0003805	CAM
29	1	0001586	CONNECTING ARM
30	1	0003819	GEARMOTOR, 8 RPM, 8 mm DIA SHAFT
31	1	0003988	OUTER MOUNTING ARM
32	1	0003989	INNER MOUNTING ARM
33	1	0003984	KNOB, MULTI-LOBE, 48 mm OD, M10 X 1.5, 40 mm LG
34	1	0001566	GRINDING WHEEL HOUSING
35	1	0003780	DC MOTOR, 12 VDC
36	1	0001553	GRINDING DISC, 152 mm OD, 6 mm THK
37	1	0001570	GRINDING DISC NUT
38	1	0003860	GRINDING WHEEL COVER PLATE
39	1	0001562	GRINDING SHIELD
40	1	0001569	DEPTH ADJUSTMENT ROD BRACKET
41	1	0001579	DEPTH ADJUSTMENT ROD, M6 X 1 THD
42	1	0003982	KNOB, CIRCULAR KNOBBED, M6 X 1, THRU
43	3	0006220	WAVE WASHER, M6
44	1	0001563	ADVANCER
45	1	0001564	ADVANCER ADJUSTMENT BLOCK

Item	Qty	Part No.	Description
46	1	0004791	CLIP, SIDE MOUNT, M6
47	1	0003983	KNOB, MULTI-LOBE, 32 mm OD, M6 X 1, 90 mm LG
48	2	0004158	OUTER BLADE SUPPORT ARM, ADJ, 570 mm LG
49	2	0004159	INNER BLADE SUPPORT ARM, 570 mm LG
50	1	0003980	KNOB, 4 LOBE, 33 mm OD, M6 X 1, 16.5 mm LG
51	2	0001907	BLADE SUPPORT, BEARING MOUNT
52	2	0004752	COTTER PIN, 1/16 in DIA, 1/2 in LG
53	1	0003132	WHETSTONE
54	1	0001561	GRINDING DISC PROFILE TEMPLATE
55	1	0004108	LABEL, TOGGLE SWITCH
56	1	0004109	LABEL, BATTERY POLARITY
57	1	0004110	LABEL, ROTATION DIRECTION
58	1	0004111	LABEL, BLADE ANGLE
59	1	0004112	LABEL, PRODUCT INFO
60	1	0004113	LABEL, QUALITY CONTROL
61	1	0004114	LABEL, WOODLAND MILLS W/ ROTATION ARROW
62	1	0004115	LABEL, MADE IN SWEDEN
63	4	626-2RS	BALL BEARING, SEALED, 6 mm SFT, 19 mm HSG, 6 mm WD
64	2	6000-2RS	BALL BEARING, SEALED, 10 mm SFT, 26 mm HSG, 8 mm WD
65	4	HHB-MBA059FCJ	HEX HEAD BOLT, CLS 8.8, M5 X 0.8, 10 mm LG, FULL
66	5	HHB-MBE067FCJ	HEX HEAD BOLT, CLS 8.8, M6 X 1, 14 mm LG, FULL
67	1	HHB-MBE080FCJ	HEX HEAD BOLT, CLS 8.8, M6 X 1, 25 mm LG, FULL
68	2	HHB-MBE085FCJ	HEX HEAD BOLT, CLS 8.8, M6 X 1, 30 mm LG, FULL
69	1	HHB-MBE095FCJ	HEX HEAD BOLT, CLS 8.8, M6 X 1, 40 mm LG, FULL
70	1	HHB-MBE115PCJ	HEX HEAD BOLT, CLS 8.8, M6 X 1, 60 mm LG, 18 mm LG THD
71	1	HHB-MBM120PCJ	HEX HEAD BOLT, CLS 8.8, M10 X 1.5, 65 mm LG, 26 mm LG THD
72	1	HFH-MBE075FCM	SCREW, HFH, CLS 10.9, M6 X 1, 20 mm LG, FULL
73	1	HFH-MBE110FCM	SCREW, HFH, CLS 10.9, M6 X 1, 55 mm LG, FULL
74	1	SHC-MBA067FCP	SHCS, CLS 12.9, M5 X 0.8, 14 mm LG, FULL
75	26	SNC-MBA063FCJ	CARRIAGE BOLT, SQ NECK, CLS 8.8, M5 X 0.8, 12 mm LG, FULL
76	1	CPS-MBE059GR	SET SCREW, CUP POINT, GR 45H, M6 X 1, 10 mm LG
77	4	PFH-MAW055FCM	SCREW, PFH, CLS 10.9, M4 X 0.7, 8 mm LG, FULL
78	2	TST-UAY011FTA	SCREW, TPH, SST, ST, NO. 8, 3/8 in LG
79	13	TST-UAY011FTB	SCREW, TPH, SST, ST, NO. 8, 3/8 in LG, BLK
80	36	FTW-MBE000AJ	FLAT WASHER, M6
81	3	FTW-MBM000AJ	FLAT WASHER, M10
82	2	FDW-MBE077000AJ	FENDER WASHER, M6, 28 mm OD
83	2	FDW-MBM077000AJ	FENDER WASHER, M10, 28 mm OD
84	20	HXN-MBACH	HEX NUT, CLS 8, M5 X 0.8
85	10	HXN-MBECH	HEX NUT, CLS 8, M6 X 1
86	1	THN-MBECC	HEX NUT, THIN, CLS 4, M6 X 1
87	1	HLN-MBMCH	LOCK NUT, CLS 8, M10 X 1.5
88	3	HLN-MBECH	LOCK NUT, CLS 8, M6 X 1
89	3	HLN-MBACH	LOCK NUT, CLS 8, M5 X 0.8
90	1	SQN-MBACF	SQUARE NUT, CLS 5, M6 X 1, 10 mm SQ
91	1	ACN-MBEAJ	ACORN NUT, M6 X 1



WOODLAND
MILLS

WE GO BEYOND.™